

EXHIBIT G

Panera Bread PUD Development Plan

Staff Report

TRAFFIC IMPACT STUDY



Traffic Impact Study

Panera Bread Dillon, Colorado

Prepared for:
Merritt and Associates GC Inc.

Kimley»»Horn



T R A F F I C I M P A C T S T U D Y

Panera Bread

Dillon, Colorado

Prepared for
Merritt and Associates GC Inc.
2102 Highways 6 & 50
Grand Junction, CO 81505

Prepared by
Kimley-Horn and Associates, Inc.
Curtis D. Rowe, P.E., PTOE
4582 South Ulster Street
Suite 1500
Denver, Colorado 80237
(303) 228-2300



September 2018

This document, together with the concepts and designs presented herein, as an instrument of service, is intended only for the specific purpose and client for which it was prepared. Reuse of and improper reliance on this document without written authorization and adaptation by Kimley-Horn and Associates, Inc. shall be without liability to Kimley-Horn and Associates, Inc.

TABLE OF CONTENTS

TABLE OF CONTENTS	i
LIST OF TABLES	ii
LIST OF FIGURES	ii
1.0 EXECUTIVE SUMMARY	1
2.0 INTRODUCTION.....	4
3.0 EXISTING AND FUTURE CONDITIONS	6
3.1 Existing Roadway Network	6
3.2 Surrounding Development	8
3.3 Existing Traffic Volumes	8
3.4 Unspecified Development Traffic Growth	8
4.0 PROJECT TRAFFIC CHARACTERISTICS.....	12
4.1 Trip Generation.....	12
4.2 Trip Distribution	12
4.3 Traffic Assignment and Total (Background Plus Project) Traffic	14
5.0 TRAFFIC OPERATIONS ANALYSIS	18
5.1 Analysis Methodology	18
5.2 Key Intersection Operational Analysis	19
5.3 Vehicle Queuing Analysis	22
6.0 CONCLUSIONS AND RECOMMENDATIONS	25

APPENDICES

- Appendix A – Intersection Count Sheets
- Appendix B – CDOT Annual Traffic Data
- Appendix C – Trip Generation Worksheets
- Appendix D – Intersection Analysis Worksheets
- Appendix E – Queueing Analysis Worksheets
- Appendix F – Conceptual Site Plan

LIST OF TABLES

Table 1 – Panera Bread Project Weekday Traffic Generation	12
Table 2 – Level of Service Definitions	18
Table 3 – Dillon Ridge Road and Full-Movement Access LOS Results	20
Table 4 – Dillon Ridge Road and US-6 LOS Results.....	21
Table 5 – Turn Lane Queuing Analysis Results.....	22

LIST OF FIGURES

Figure 1 – Vicinity Map.....	5
Figure 2 – Existing Lane Configurations.....	7
Figure 3 – Existing Traffic Volumes.....	9
Figure 4 – 2020 Background Traffic Volumes.....	10
Figure 5 – 2040 Background Traffic Volumes.....	11
Figure 6 – Project Trip Distribution	13
Figure 7 – Project Traffic Assignment	15
Figure 8 – 2020 Background Plus Project Traffic Volumes.....	16
Figure 9 – 2040 Background Plus Project Traffic Volumes.....	17
Figure 10 – Recommended Lane Configurations and Control	24

1.0 EXECUTIVE SUMMARY

A Panera Bread restaurant is proposed within The Ridge at Dillon retail center along the north side of Dillon Ridge Road, north of US-6 in Dillon, Colorado. For purposes of this traffic evaluation, the project was studied to include an approximate 4,500 square foot fast food restaurant with drive-through window. It is expected that project construction will be completed within the next couple of years. Analysis was therefore completed for the 2020 short term build out horizon as well as the 2040 long-term twenty-year horizon.

The purpose of this study is to identify project traffic generation characteristics, to identify potential project traffic related impacts on the local street system, and to develop mitigation measures required for identified impacts. The following intersections were incorporated into this traffic study in accordance with Town of Dillon and State of Colorado Department of Transportation (CDOT) standards and requirements:

- Dillon Ridge Road Full-Movement Access
- US Highway 6 and Dillon Ridge Road

Regional access to the project will be provided by Interstate 70 (I-70) and US-6. Primary and direct access to The Ridge at Dillon has and will continue to be provided by Dillon Ridge Road. An existing full-movement access to the project site exists along Dillon Ridge Road, approximately 375 feet north of the US-6 and Dillon Ridge Road intersection (measured center to center). The project is expected to generate a total of approximately 2,120 daily weekday trips with 181 of these trips occurring during the morning peak hour and 147 new trips during the afternoon peak hour. The Saturday peak hour of generator includes 247 total trips with 126 trips entering and 121 trips exiting.

Distribution of site traffic on the street system was based on the area street system characteristics, existing traffic patterns, demographic information, anticipated surrounding development areas, and the proposed access system for the project. Assignment of traffic was based upon the trip generation described previously and the distributions developed. The traffic assignment was added to the background traffic volumes to determine future traffic with the project.

Based on the analysis presented in this report, Kimley-Horn believes the proposed Panera Bread in Dillon, Colorado will be successfully incorporated into the existing and future roadway network. The proposed project development and expected traffic volumes resulted in the following recommendations and conclusions:

- It is recommended the intersection of Dillon Ridge Road and the full movement project access be improved to include All-Way Stop Control. R1-1 “STOP” signs should be installed on the eastbound and westbound approaches. In addition, R1-4 “ALL WAY” plaques should be installed underneath all four “STOP” signs. Since this will be a change in control unfamiliar to drivers traveling along Dillon Ridge Road, it is recommended that two red flags be affixed to the top of the new “STOP” signs at 45-degree angles for the new stop control on the eastbound and westbound approaches. These flags should remain for a period of approximately three to six months.
- Additional operational improvements should be considered for the Dillon Ridge Road access intersection by adding striping to the north leg of this access to designate a separate left turn lane. It is believed that the existing driveway is wide enough to designate three lanes with one entering lane and two exiting lanes (a separate left turn and a shared through/right turn lane). This will improve operations of the intersection by processing two vehicles out of the access at the same time under the recommended all way stop control condition.
- With development of the project, it is recommended that the 65-foot eastbound left turn lane at the Dillon Ridge Road full movement access intersection be restriped to include 100 feet of storage length. Incorporation of all-way stop control and striping the southbound approach to include separate left turn and shared through/right turn lanes will help alleviate the queue issues for traffic exiting The Ridge at Dillon retail center. However, it is anticipated that the existing 25-foot throat depth may be exceeded during the Saturday midday peak hour. The all-way stop control will allow traffic to continue moving. If traffic exiting from the Walgreens to the east blocks entering traffic into the retail center, operations could be improved by closing off the first drive aisle to the Walgreen's site. This could be considered if found to be needed.

- Unrelated to this project, a traffic deficiency exists for the northbound left turn at the US-6 and Dillon Ridge Road/Anemone Trail intersection. Acceptable operations result, however the northbound left turn queue may extend through the Little Dam Street intersection to the south during the peak hours. This is likely why there are separate left turn and a shared left turn/through lane on the northbound approach at the US-6 signalized intersection today to address left turn movements in two lanes. If possible, raised pork chop island channelization for the eastbound right turn lane (deceleration and acceleration) could be added so that the stop bar on the south leg could be moved further north. This would allow for the northbound approach to have an extended queue space on this approach due to the absence of a crosswalk on this leg. If channelizing islands were added to the north side of US-6 as well, the pedestrian crossing distance of the west leg would be significantly reduced, which would improve signal operations, as well as an overall improvement with a true free southbound right turn. These improvements could be considered by CDOT and the Town of Dillon if desired as it is understood that this may impact snow removal operations during the winter.
- By year 2040 the 65-foot eastbound left turn lane at the Dillon Ridge Road and full movement access intersection may need to be restriped to include 100 feet of storage length.
- All on-site and off-site roadway, signing, striping, and signal improvements should be incorporated into the Civil Drawings, and conform to Town of Dillon and Colorado Department of Transportation standards as well as the Manual on Uniform Traffic Control Devices – 2009 Edition (MUTCD).

2.0 INTRODUCTION

Kimley-Horn and Associates, Inc. (Kimley-Horn) has prepared this report to document the results of a Traffic Impact Study of future traffic conditions associated with a proposed Panera Bread project proposed within The Ridge at Dillon retail center. The project will include constructing a new restaurant building within the existing Ridge at Dillon along the north side of Dillon Ridge Road, north of US-6, in Dillon, Colorado. A vicinity map illustrating the location of the project site is shown in **Figure 1**.

For purposes of this traffic evaluation, the project was studied to include an approximate 4,500 square foot fast food restaurant with a drive-through window. A conceptual site plan of the project is provided within **Appendix F**. It is expected that project construction will be completed within the next two years. Analysis was therefore completed for the 2020 short term build out horizon as well as the 2040 long-term horizon.

The purpose of this study is to identify project traffic generation characteristics, to identify potential project traffic related impacts on the local street system, and to develop mitigation measures required for identified impacts. The following intersections were incorporated into this traffic study in accordance with Town of Dillon and State of Colorado Department of Transportation (CDOT) standards and requirements:

- Dillon Ridge Road Full-Movement Access
- US Highway 6 and Dillon Ridge Road

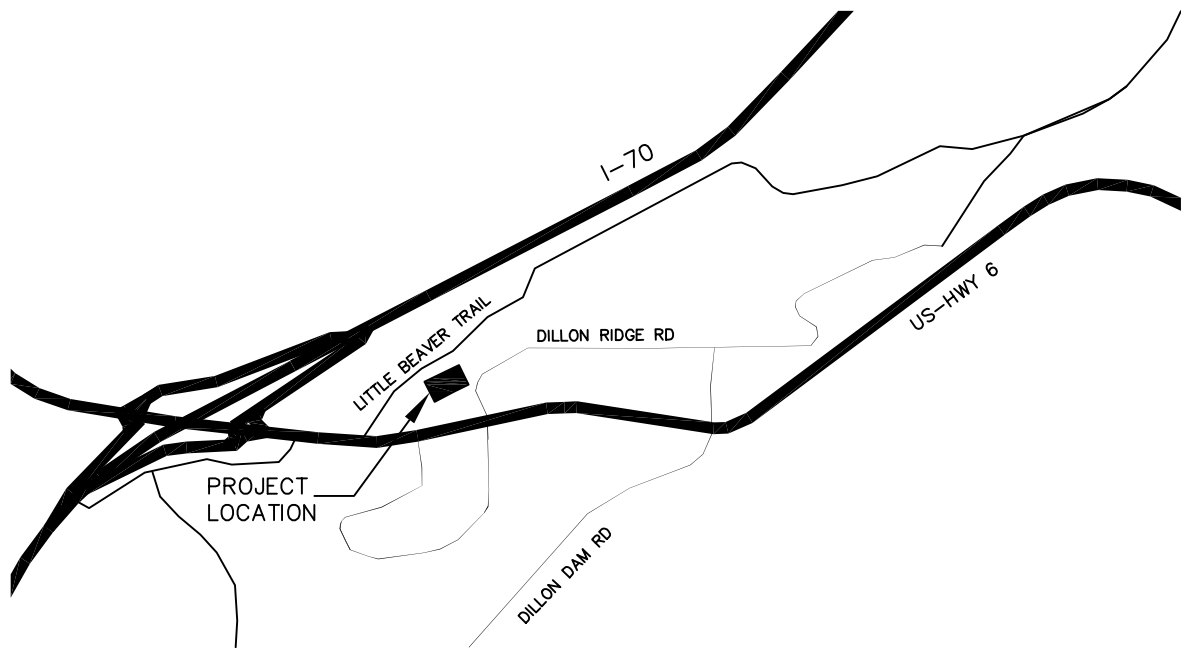

PANERA BREAD DILLON
VICINITY MAP

FIGURE 1

3.0 EXISTING AND FUTURE CONDITIONS

3.1 Existing Roadway Network

Regional access to the project will be provided by Interstate 70 (I-70) and US-6. Primary and direct access to The Ridge at Dillon has and will continue to be provided by Dillon Ridge Road. An existing full-movement access to the project site exists along Dillon Ridge Road, approximately 375 feet north of the US-6 and Dillon Ridge Road intersection (center to center).

US Highway 6 is a CDOT Highway, categorized NR-B: Non-Rural Arterial that provides two through lanes of travel eastbound and westbound in the vicinity of the site. US-6 has a 35 mile per hour speed limit to the west of the US-6 and Dillon Ridge Road intersection and a 40 mile per hour speed limit to the east of the US-6 and Dillon Ridge Road intersection. Dillon Ridge Road provides one through lane of travel northbound and southbound with a 25 mile per hour speed limit through the study area. Additionally, Dillon Ridge Road has an existing striped median throughout the project area that transitions to left turn lanes at access intersections in the site vicinity.

The intersection of US-6 and Dillon Ridge Road is currently signalized with protected-permitted left turn phasing on the eastbound and westbound US-6 approaches and split phasing on the northbound and southbound Dillon Ridge Road/Anemone Trail approaches. The eastbound and westbound approaches on US-6 provide a left turn lane, two through lanes, and a right turn lane. Acceleration lanes from right turn movements of the side street access approaches also exist at this intersection along US-6. The northbound approach on Anemone Trail provides a left turn lane, a shared left turn/through lane, and a right turn lane. The southbound approach on Dillon Ridge Road provides a shared through/left turn lane and a right turn lane.

The Dillon Ridge Road access intersection is a four-leg intersection that operates with stop-control on the northbound and southbound site access approaches. The northbound and southbound approaches of this intersection are undesignated and provide a single lane, although they are wide enough to stripe separate left turn and right turn lanes. The eastbound and westbound approaches on Dillon Ridge Road provide a left turn lane and a shared through/right turn lane. The intersection lane configurations and control for the existing study area intersections are shown in **Figure 2**.

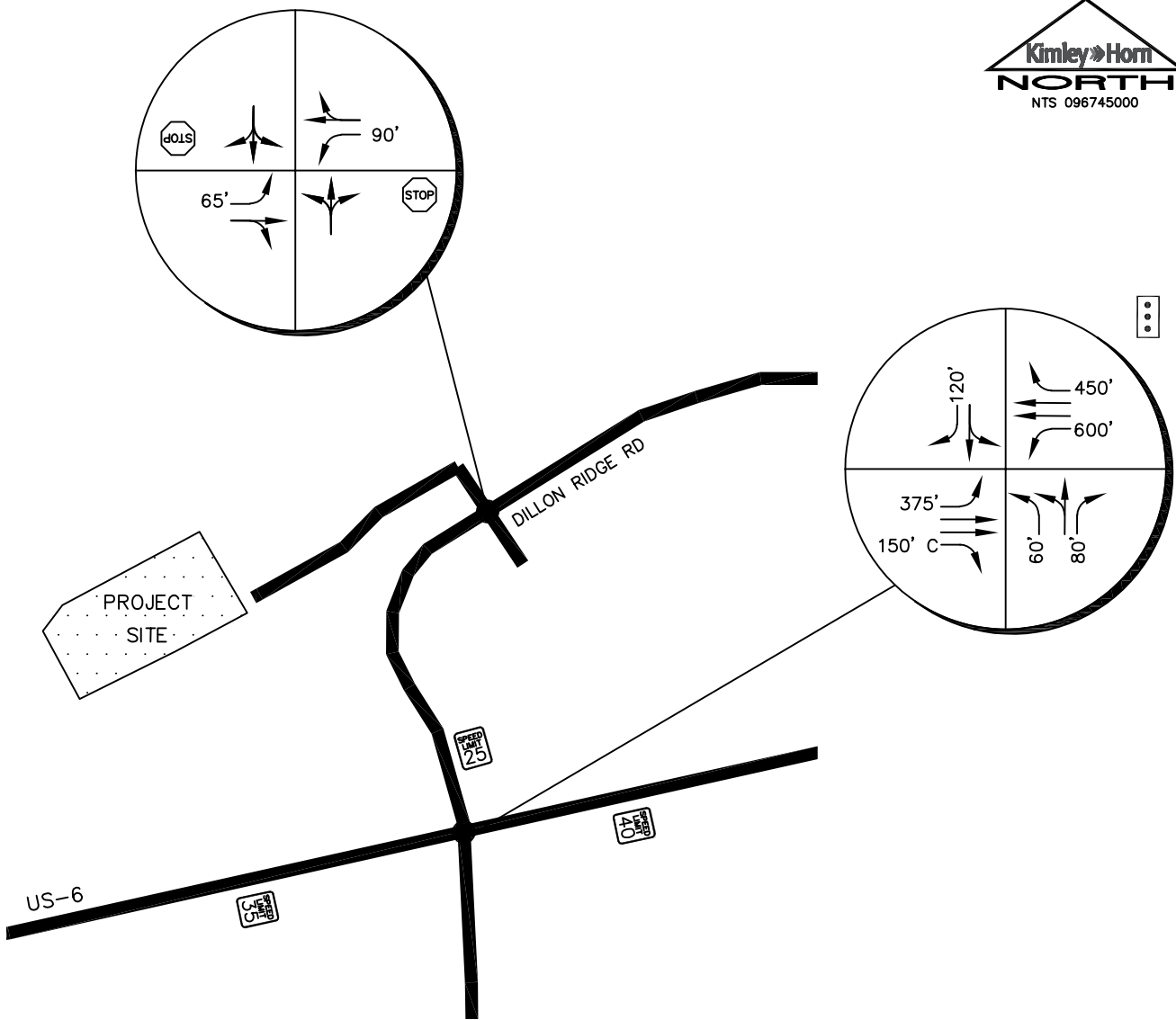

LEGEND	
	Study Area Key Intersection
	Signalized Intersection
	Stop Controlled Approach
	Roadway Speed Limit
C	Continuous Turn Lane
	100' Turn Lane Length (feet)

PANERA BREAD DILLON
 EXISTING LANE CONFIGURATIONS

FIGURE 2

3.2 Surrounding Development

The proposed Panera Bread is to be located within the existing The Ridge at Dillon, located along the north side of Dillon Ridge Road. The existing commercial center includes several fast-casual restaurants, retail shops, and a parking lot. The access for this commercial center is shared with a Walgreens. Alpine Bank is located along the south side of Dillon Ridge Road with its access aligning at this intersection. The surrounding area is essentially fully built out and contains a mix of uses with commercial uses located to the east, west, and south of the proposed site along US-6. I-70 borders the development to the north. On the other side of I-70 more commercial uses exist, as well as hotels. Residential developments are located further to the north and east. Dillon Reservoir exists to the south.

3.3 Existing Traffic Volumes

Existing peak hour turning movement counts were conducted at the key intersections on Tuesday, July 10, 2018 during the weekday morning and afternoon peak hours and on Saturday, September 1, 2018 during the weekend midday peak hour. The weekday counts were conducted in 15-minute intervals during the morning and afternoon peak hours of adjacent street traffic from 7:00 AM to 9:00 AM and 4:00 PM to 6:00 PM. The Saturday counts were conducted in 15-minute interval during the midday peak hour from 11:30 AM to 1:30 PM. The turning movement counts are shown in **Figure 3** with count sheets provided in **Appendix A**.

3.4 Unspecified Development Traffic Growth

According to information provided on the CDOT transportation information website, the 20-year growth factor along US-6 in the vicinity of the project is 1.26. This equates to an annual growth rate of approximately 1.16 percent. US-6 traffic information from the CDOT Online Transportation Information System (OTIS) website is included in **Appendix B**. Due to this, a more conservative annual growth rate of 1.5 percent was used to calculate future through traffic volumes along US-6. Since the area surrounding the proposed development is fully built out, no additional traffic volume growth is expected. The annual growth rate was used to estimate near term 2020 and long term 2040 traffic volume projections at the US-6 key intersection. Background traffic volumes for 2020 and 2040 are shown in **Figures 4** and **Figure 5**, respectively.

Tuesday, July 10 2018
 8:00 to 9:00 AM (4:00 to 5:00 PM)
 [Saturday, Sept. 1, 2018]
 [12:30 to 1:30 PM]

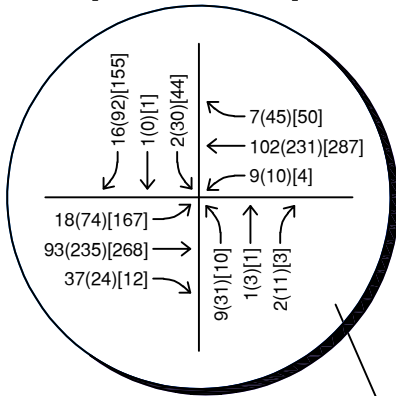

Tuesday, July 10 2018
 8:00 to 9:00 AM (4:15 to 5:15 PM)
 [Saturday, Sept. 1, 2018]
 [12:30 to 1:30 PM]

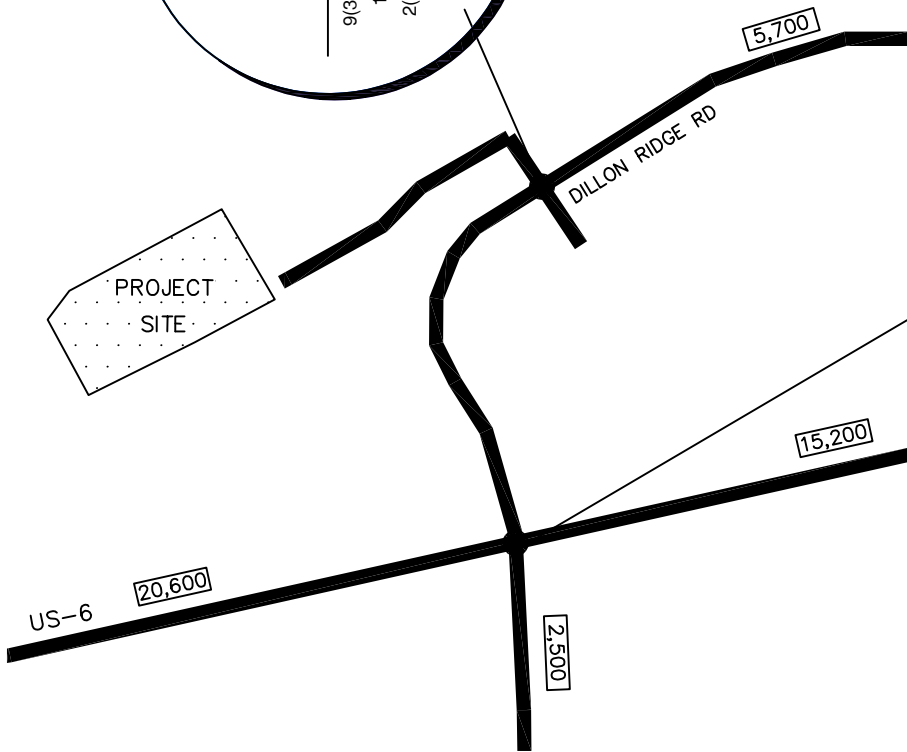
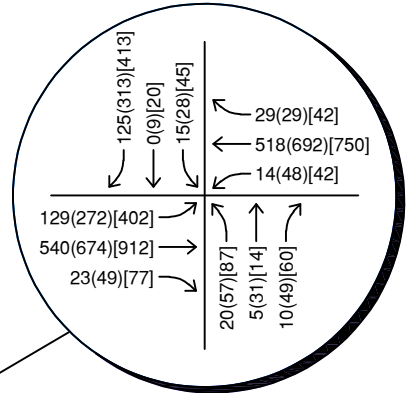

LEGEND

- Study Area Key Intersection
- xxx(xxx)[xxx] Weekday AM(PM) [Weekend] Peak Hour Traffic Volumes
- xx,x00 Estimated Weekday Daily Traffic Volume

PANERA BREAD DILLON
 EXISTING TRAFFIC VOLUMES

FIGURE 3



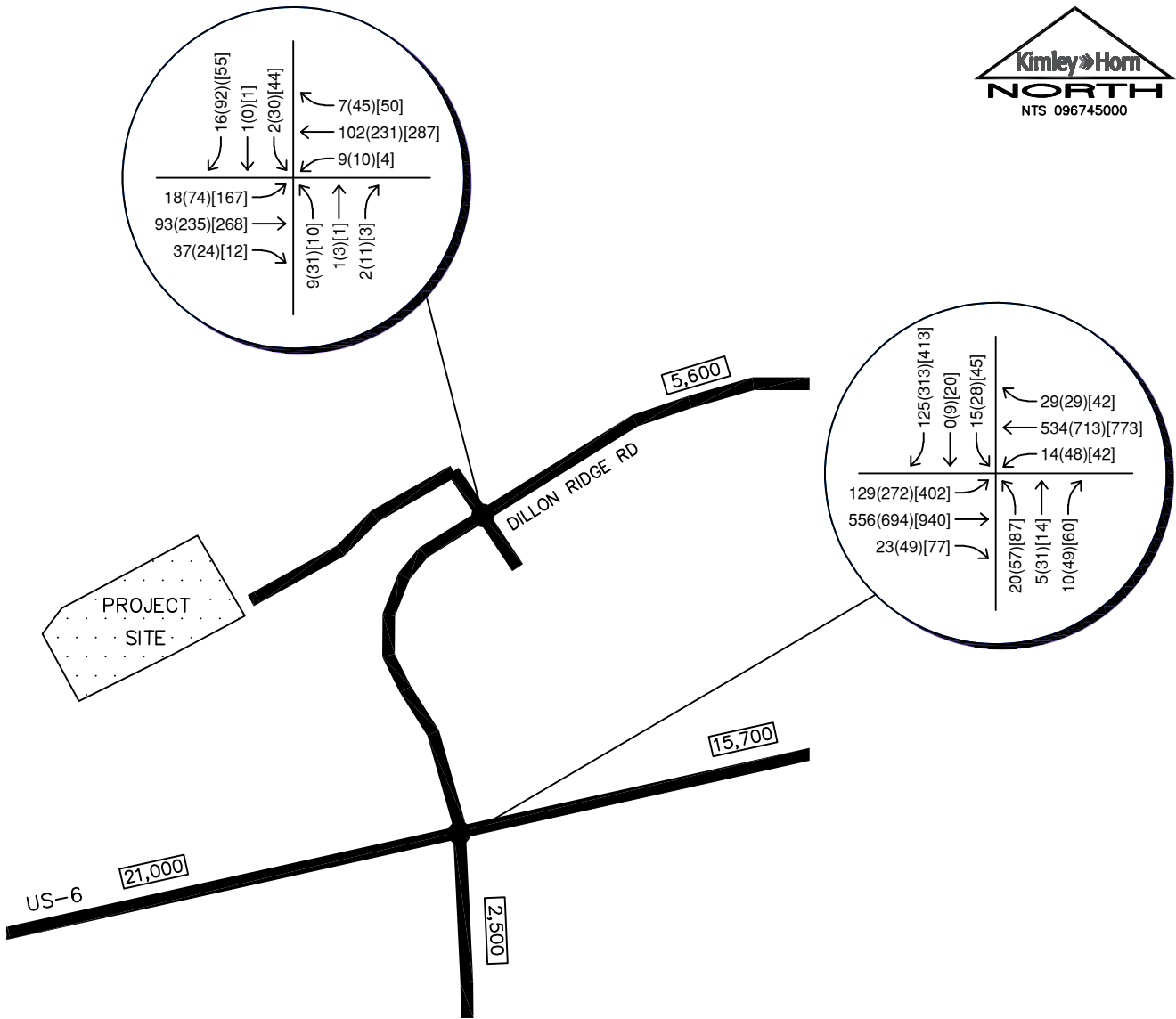

LEGEND

- Study Area Key Intersection
- xxx(yyy)[zzz] Weekday AM(PM) [Weekend] Peak Hour Traffic Volumes
- xx,x00 Estimated Weekday Daily Traffic Volume

PANERA BREAD DILLON
 2020 BACKGROUND TRAFFIC VOLUMES

FIGURE 4

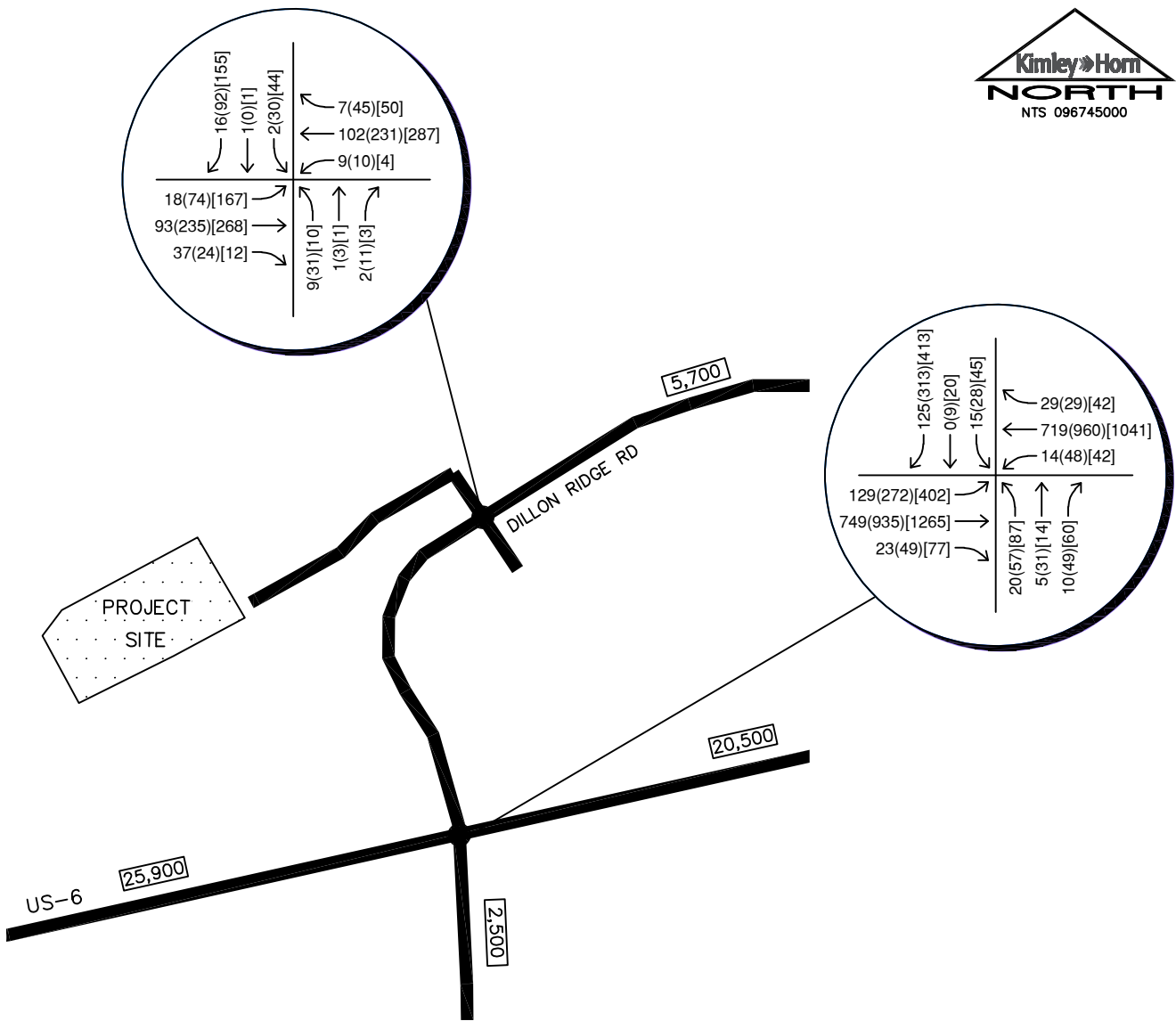

LEGEND

●	Study Area Key Intersection
xxx(xxx)[xxx]	Weekday AM(PM) [Weekend] Peak Hour Traffic Volumes
xx,x00	Estimated Weekday Daily Traffic Volume

PANERA BREAD DILLON
 2040 BACKGROUND TRAFFIC VOLUMES

FIGURE 5

4.0 PROJECT TRAFFIC CHARACTERISTICS

4.1 Trip Generation

Site-generated traffic estimates are determined through a process known as trip generation. Rates and equations are applied to the proposed land use to estimate traffic generated by the development during a specific time interval. The acknowledged source for trip generation rates is the *Trip Generation Report*¹ published by the Institute of Transportation Engineers (ITE). ITE has established trip rates in nationwide studies of similar land uses. For this study, Kimley-Horn used the ITE Trip Generation Report average rate equations that apply to Fast-Food Restaurant with Drive-Through Window (ITE 934) for traffic associated with the development. **Table 1** provides the estimated trip generation for the proposed Panera Bread Dillon development.

Table 1 – Panera Bread Project Weekday Traffic Generation

Uses	Vehicle Trips									
	Daily	Weekday AM Peak Hour			Weekday PM Peak Hour			Saturday Peak Hour of Generator		
		In	Out	Total	In	Out	Total	In	Out	Total
Fast Food Restaurant with Drive-Through (ITE 934) – 4,500 Square Feet	2,120	92	89	181	76	71	147	126	121	247

As shown in **Table 1**, the project is expected to generate a total of approximately 2,120 daily weekday trips with 181 of these trips occurring during the morning peak hour and 147 new trips during the afternoon peak hour. The Saturday peak hour of generator includes 247 total trips with 126 trips entering and 121 trips exiting.

4.2 Trip Distribution

Distribution of site traffic was based on the area street system characteristics, existing traffic patterns and volumes, existing demographic information, and the proposed access system for the project. The directional distribution of traffic is a means to quantify the percentage of site-generated traffic that approaches the site from a given direction and departs the site back to the original source. **Figure 6** illustrates the expected trip distribution for the site trips.

¹ Institute of Transportation Engineers, *Trip Generation: An Information Report*, Tenth Edition, Washington DC, 2017.

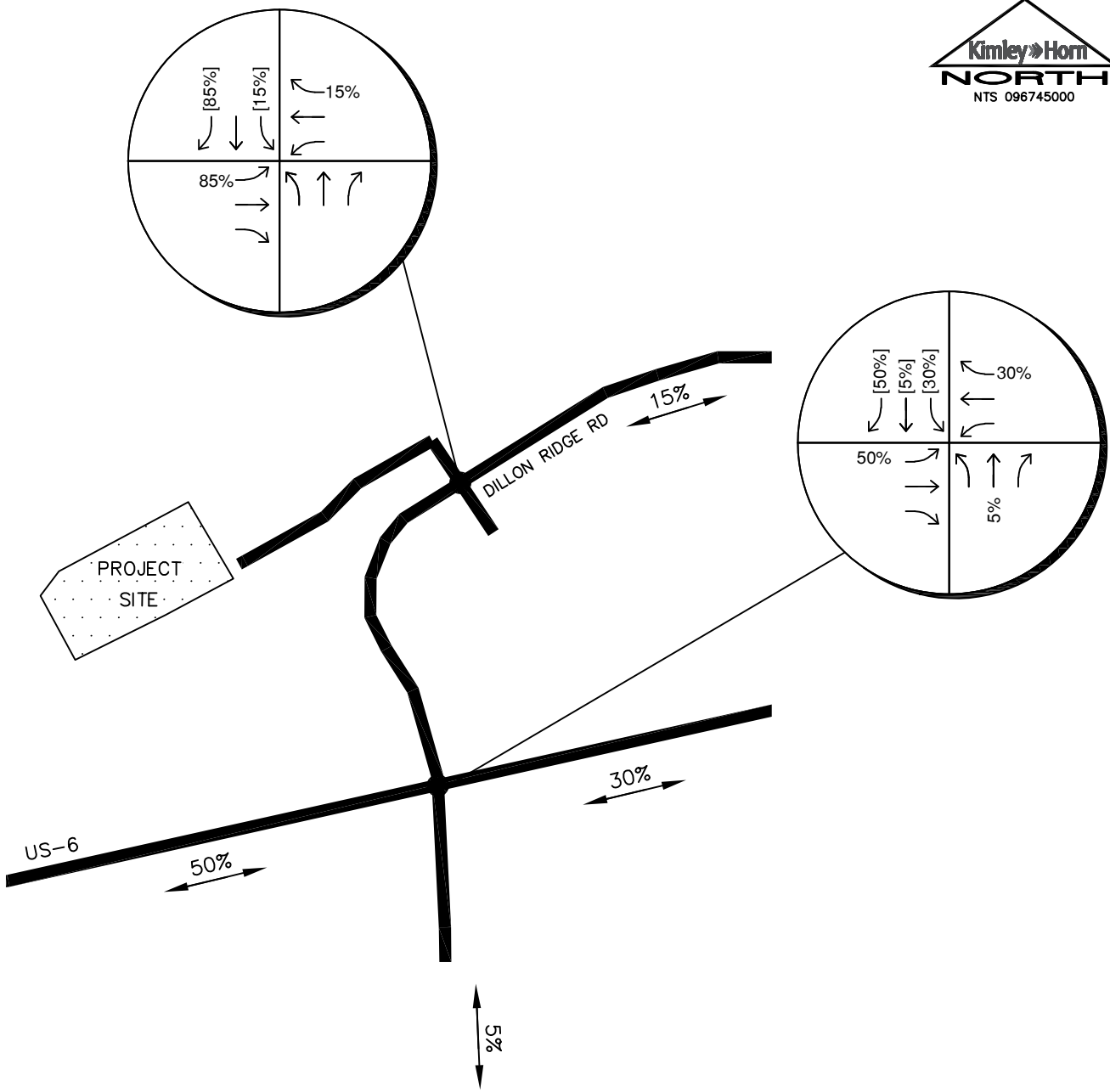

LEGEND

- Study Area Key Intersection

XX%[XX%] Entering[Exiting] Trip Distribution Percentage

PANERA BREAD DILLON
 PROJECT TRIP DISTRIBUTION

FIGURE 6

4.3 Traffic Assignment and Total (Background Plus Project) Traffic

Traffic assignment was obtained by applying the project trip distribution to the estimated traffic generation of the development shown in **Table 1**. Project traffic assignment during the peak hours studied is shown in **Figure 7**. Project traffic volumes were added to the background volumes to represent estimated traffic conditions for the short term 2020 horizon and long term 2040 horizon. These background plus project (total) traffic volumes for the project are illustrated for the 2020 and 2040 horizon years in **Figures 8** and **9**, respectively.

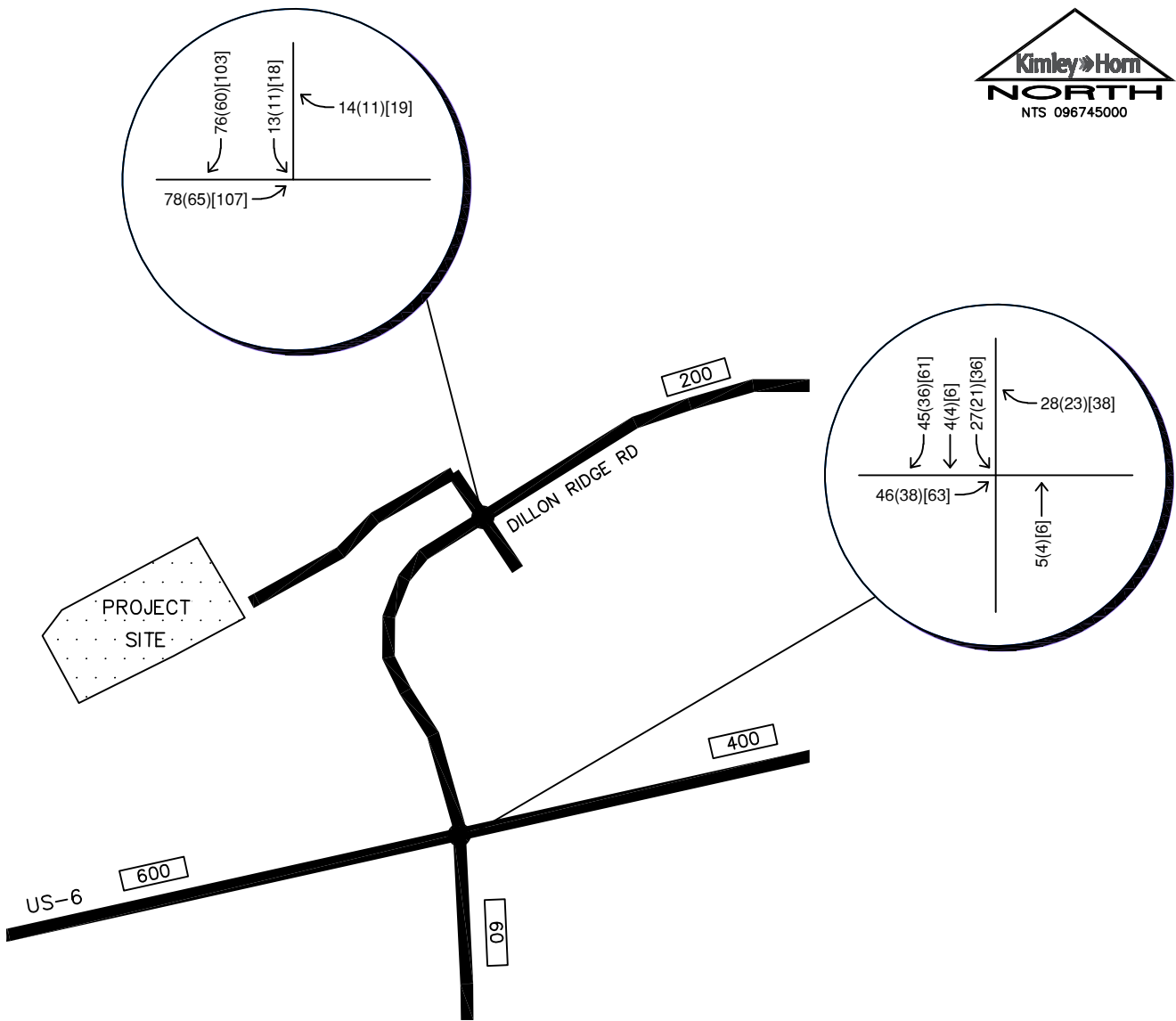

LEGEND	
●	Study Area Key Intersection
xxx(XXX)[xxx]	Weekday AM(PM) [Weekend] Peak Hour Traffic Volumes
xx,x00	Estimated Weekday Daily Traffic Volume

PANERA BREAD DILLON
 PROJECT TRAFFIC ASSIGNMENT

FIGURE 7

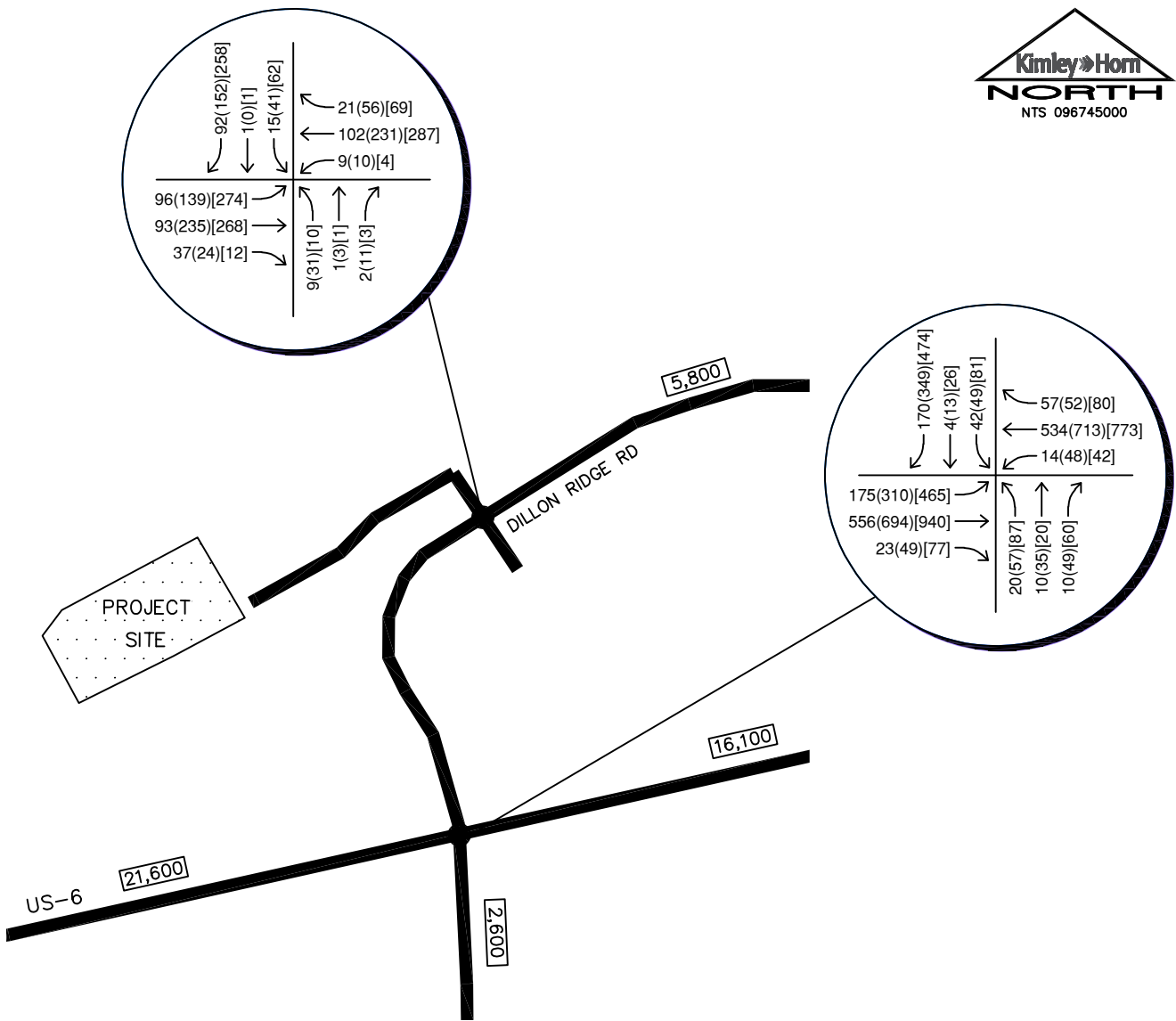

LEGEND

- Study Area Key Intersection
- xxx(xxx)[xxx] Weekday AM(PM) [Weekend] Peak Hour Traffic Volumes
- xx,x00 Estimated Weekday Daily Traffic Volume

PANERA BREAD DILLON
 2020 BACKGROUND TRAFFIC PLUS
 PROJECT TRAFFIC VOLUMES

FIGURE 8

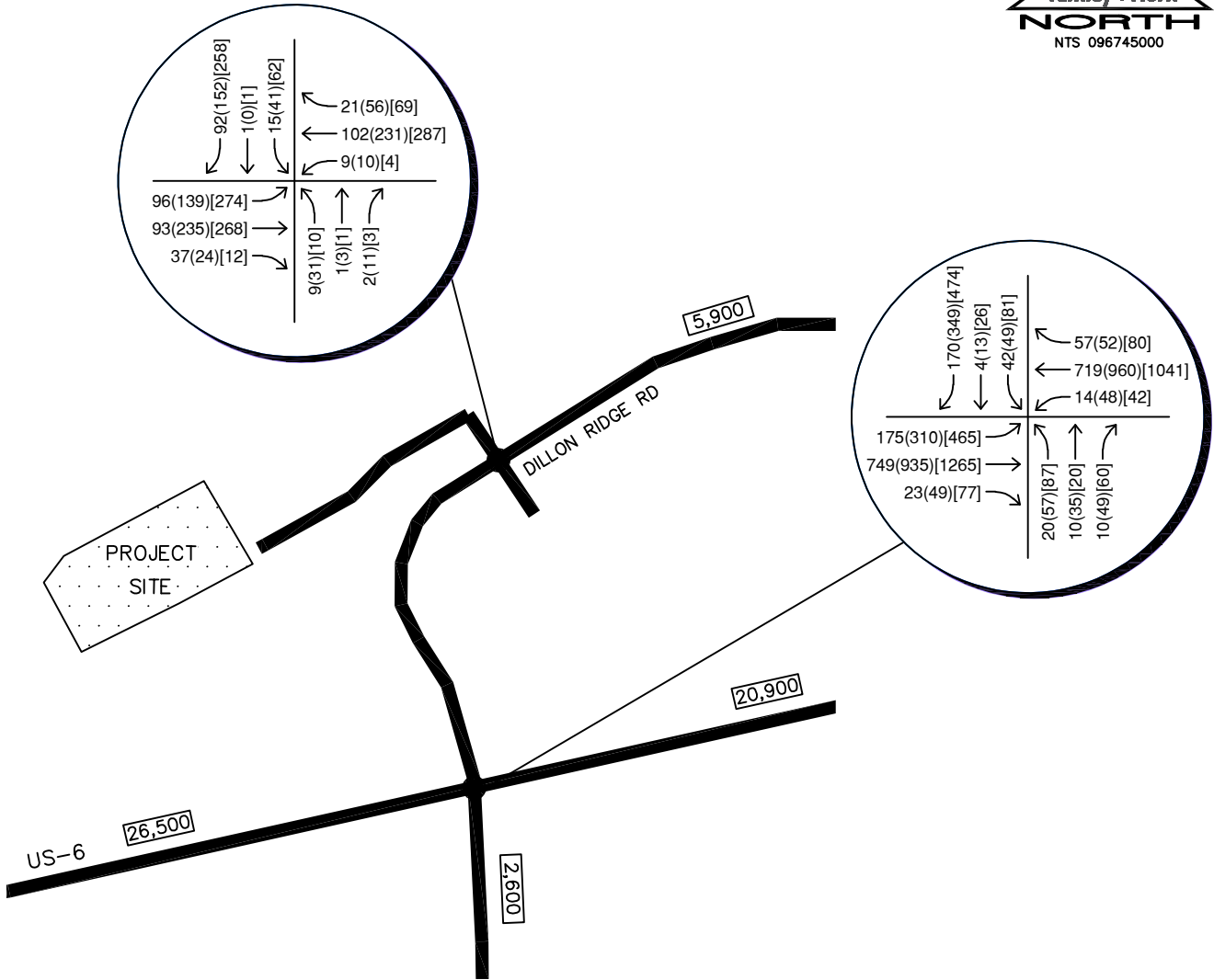

LEGEND

- Study Area Key Intersection
- xxx(xxx)[xxx] Weekday AM(PM) [Weekend] Peak Hour Traffic Volumes
- xx,x00 Estimated Weekday Daily Traffic Volume

PANERA BREAD DILLON
 2040 BACKGROUND TRAFFIC PLUS
 PROJECT TRAFFIC VOLUMES

FIGURE 9

5.0 TRAFFIC OPERATIONS ANALYSIS

Kimley-Horn’s analysis of traffic operations in the site vicinity was conducted to determine potential capacity deficiencies in the 2020 and 2040 development horizons at the identified key intersections and access driveways. The acknowledged source for determining overall capacity is the current 6th edition of the *Highway Capacity Manual (HCM)*².

5.1 Analysis Methodology

Capacity analysis results are listed in terms of Level of Service (LOS). LOS is a qualitative term describing operating conditions a driver will experience while traveling on a particular street or highway during a specific time interval. It ranges from A (very little delay) to F (long delays and congestion). For intersections and roadways in this study area, standard traffic engineering practice identifies overall intersection LOS D and movement LOS E as the minimum threshold for acceptable operations. **Table 2** shows the definition of level of service for signalized and unsignalized intersections.

Table 2 – Level of Service Definitions

Level of Service	Signalized Intersection Average Total Delay (sec/veh)	Unsignalized Intersection Average Total Delay (sec/veh)
A	≤ 10	≤ 10
B	> 10 and ≤ 20	> 10 and ≤ 15
C	> 20 and ≤ 35	> 15 and ≤ 25
D	> 35 and ≤ 55	> 25 and ≤ 35
E	> 55 and ≤ 80	> 35 and ≤ 50
F	> 80	> 50

Study area intersections were analyzed based on average total delay analysis for signalized and unsignalized intersections. Under the unsignalized analysis, the level of service (LOS) for a two-way stop controlled intersection is determined by the computed or measured control delay and is defined for each minor movement. Level of service for a two-way stop-controlled intersection is not defined for the intersection as a whole. Level of service for a signalized and four-way stop controlled intersection is defined for each approach and for the intersection.

² Transportation Research Board, *Highway Capacity Manual*, Sixth Edition, Washington DC, 2016.

5.2 Key Intersection Operational Analysis

Calculations for the level of service at the key intersections identified for this study are provided in **Appendix D**. The existing and background traffic analyses are based on the lane geometry and intersection control shown in **Figure 2**. The signalized intersection analysis utilizes the observed cycle lengths for the peak hours with existing phasing and optimized timing splits. Synchro 10 traffic analysis software was used to analyze the study intersections for level of service. The Synchro Highway Capacity Manual (HCM) methodology reports were used to analyze intersection delay and level of service.

Dillon Ridge Road Full-Movement Access

The existing full movement access intersection along Dillon Ridge Road for The Ridge at Dillon is a four-leg intersection that operates with stop-control on the northbound and southbound commercial access approaches. The northbound and southbound access approaches of this intersection are unmarked and provide a single approach lane. The westbound and eastbound approaches on Dillon Ridge Road provide a left turn lane and a shared through/right turn lane.

With the existing lane configuration and control at the Dillon Ridge Road Access intersection all movements currently operate acceptably with LOS C or better during the weekday peak hours and LOS D or better during the Saturday peak hour. With the addition of project traffic, heavy delays are expected on the northbound and southbound approaches with a LOS F during the Saturday peak hour of generator if the existing configuration and two-way stop control remained. Therefore, it is recommended that the Dillon Ridge Road access intersection be converted to All-Way Stop Control with the addition of R1-1 "STOP" signs on the eastbound and westbound approaches with development of the project. In addition, R1-4 "ALL WAY" plaques should be installed underneath all four "STOP" signs. Since this will be a change in control unfamiliar to drivers traveling along Dillon Ridge Road, it is recommended that two red flags be affixed to the top of the new "STOP" signs at 45-degree angles for the new stop control on the eastbound and westbound approaches. These flags should remain for a period of approximately three to six months. Additional operational improvements include adding striping to the north leg of this access to designate a separate left turn lane. It is believed that the existing driveway is wide enough to designate three lanes with one entering lane and two exiting lanes (a separate left turn and a shared through/right turn lane). This will improve operations of the intersection by processing two vehicles out of the access at the same time under the

recommended all way stop control condition. With these improvements, the intersection is expected to operate acceptably during the weekday peak hours with LOS B and during the Saturday peak hour with LOS D. **Table 3** provides the results of the level of service at this intersection.

Table 3 – Dillon Ridge Road and Full-Movement Access LOS Results

Scenario	AM Peak Hour		PM Peak Hour		Saturday Peak Hour	
	Delay (sec)	LOS	Delay (sec)	LOS	Delay (sec)	LOS
2018 Existing						
Northbound Approach	11.5	B	19.3	C	34.0	D
Eastbound Left	7.5	A	8.1	A	8.8	A
Westbound Left	7.6	A	7.9	A	7.9	A
Southbound Approach	9.9	A	15.0	C	27.8	D
Background Plus Project						
Northbound Approach	18.1	C	29.1	D	89.1	F
Eastbound Left	7.8	A	8.3	A	9.5	A
Westbound Left	7.6	A	7.9	A	7.9	A
Southbound Approach	13.9	B	21.6	C	161.9	F
Background Plus Project #	10.1	B	13.7	B	25.9	D
Northbound Approach	9.6	A	11.6	B	12.5	B
Eastbound Approach	10.3	B	13.5	B	19.9	C
Westbound Approach	10.0	A	15.9	C	41.6	E
Southbound Approach	9.8	A	11.9	B	16.8	C

Includes All-Way Stop Control and Southbound Left Turn Lane

Dillon Ridge Road and US-6

The intersection of Dillon Ridge Road and US-6 is currently signalized with protected/permitted left turn phasing on the major westbound and eastbound approaches. The minor northbound and southbound approaches operate with split phasing.

The eastbound and westbound approaches on US-6 provide one left turn lane, two through lanes, and a right turn lane. The southbound approach on Dillon Ridge Road provides a shared through/left turn lane and a right turn lane. The northbound Anemone Trail approach provides a left turn lane, a shared through/left turn lane, and a right turn lane.

Currently, this intersection operates acceptably during the weekday morning and afternoon peak hours and Saturday midday peak hour with LOS B. With the addition of project traffic, this intersection is expected to operate acceptably with level of service C or better in the buildout year of 2020 during the three peak hours studied. By 2040, this intersection is anticipated to continue to operate acceptably with LOS C during the studied peak hours. **Table 4** provides the results of the level of service at this intersection.

Table 4 – Dillon Ridge Road and US-6 LOS Results

Scenario	AM Peak Hour		PM Peak Hour		Saturday Peak Hour	
	Delay (sec)	LOS	Delay (sec)	LOS	Delay (sec)	LOS
2018 Existing	13.9	B	18.5	B	17.3	B
2020 Background	13.8	B	19.7	B	17.4	B
2020 Background Plus Project	23.2	C	31.0	C	24.1	C
2040 Background	25.0	C	31.9	C	25.2	C
2040 Background Plus Project	26.1	C	32.4	C	29.7	C

5.3 Vehicle Queuing Analysis

Queuing analysis was conducted for the study area intersections. Results were obtained from the 95th percentile queue lengths obtained from the Synchro analysis. Queue analysis worksheets at the US-6 and Dillon Ridge Road signalized intersection is provided in **Appendix E**. Queue length calculations for the unsignalized access intersection is provided within the level of service operational sheets provided in **Appendix D**. Results of the queuing analysis and recommendations at the study area intersections are provided in **Table 5**.

Table 5 – Turn Lane Queuing Analysis Results

Intersection Turn Lane	Existing Turn Lane Length (feet)	2020 Calculated Queue (feet)	2020 Recommended Length (feet)	2040 Calculated Queue (feet)	2040 Recommended Length (feet)
Dillon Ridge Road Access #					
Northbound Approach	25'	25'	25'	25'	25'
Eastbound Left	65'	100'	100'	100'	100'
Eastbound Through	C	100'	C	100'	C
Westbound Left	90'	25'	90'	25'	90'
Westbound Through	C	250'	C	250'	C
Southbound Left	25'	25'	25'	25'	25'
Southbound Through/Right	25'	100'	25'	100'	25'
Dillon Ridge Road and US-6					
Eastbound Left	375'	459'	375'	552'	375'
Eastbound Right	150' C	25'	150' C	26'	150' C
Westbound Left	600'	28'	600'	33'	600'
Westbound Right	450'	36'	450'	37'	450'
Northbound Left	60'	115'	125'	122'	125'
Northbound Right	80'	27'	80'	27'	80'
Southbound Right	120'	89'	120'	90'	120'

All Way Stop Control; C = Continuous Through Lane

As shown in the table representing the queuing results, all vehicle queues are anticipated to be accommodated or managed within existing turn bay lengths by project buildout in 2020 with exception of the eastbound left turn and southbound through/right turn at the Dillon Ridge Road Access intersection as well as the eastbound left turn and northbound left turn at the Dillon Ridge Road and US-6 intersection.

With development of the project, it is recommended that the 65-foot eastbound left turn lane at the Dillon Ridge Road full movement access intersection be restriped to include 100 feet of storage length. Incorporation of all-way stop control and striping the southbound approach to

include separate left turn and shared through/right turn lanes will help alleviate the queue issues for traffic exiting The Ridge at Dillon retail center. However, it is anticipated that the existing 25-foot throat depth may be exceeded during the Saturday midday peak hour. The all-way stop control will allow traffic to continue moving. If traffic exiting from the Walgreens to the east blocks entering traffic into the retail center, operations could be improved by closing off the first drive aisle to the Walgreen's site. This could be considered if found to be needed.

At the Dillon Ridge Road and US-6 intersection, the eastbound left turn lane may experience long queues during the Saturday peak hour of generator. However, this left turn lane is constructed to its maximum length and cannot be further extended due to the geometric constraints from the Anemone Trail and US-6 three-quarter access intersection located approximately 500 feet west of the Dillon Ridge Rd and US-6 intersection (measured center to center). Therefore, it is believed that this left turn lane will need to remain with a length of 375 feet.

Unrelated to this project, a traffic deficiency exists for the northbound left turn at the US-6 and Dillon Ridge Road/Anemone Trail intersection. Acceptable operations result, however the northbound left turn queue may extend through the Little Dam Street intersection to the south during the peak hours. This is likely why there are separate left turn and a shared left turn/through lane on the northbound approach at the US-6 signalized intersection today to address left turn movements in two lanes. If possible, raised pork chop island channelization for the eastbound right turn lane (deceleration and acceleration) could be added so that the stop bar on the south leg could be moved further north. This would allow for the northbound approach to have an extended queue space on this approach due to the absence of a crosswalk on this leg. If channelizing islands were added to the north side of US-6 as well, the pedestrian crossing distance of the west leg would be significantly reduced, which would improve signal operations, as well as an overall improvement with a true free southbound right turn. These improvements could be considered by CDOT and the Town of Dillon if desired as it is understood that this may impact snow removal operations during the winter.

Based on the results of the intersection operational and queuing analysis, the recommended lane configurations and control of the study key intersections are shown in **Figure 10**.

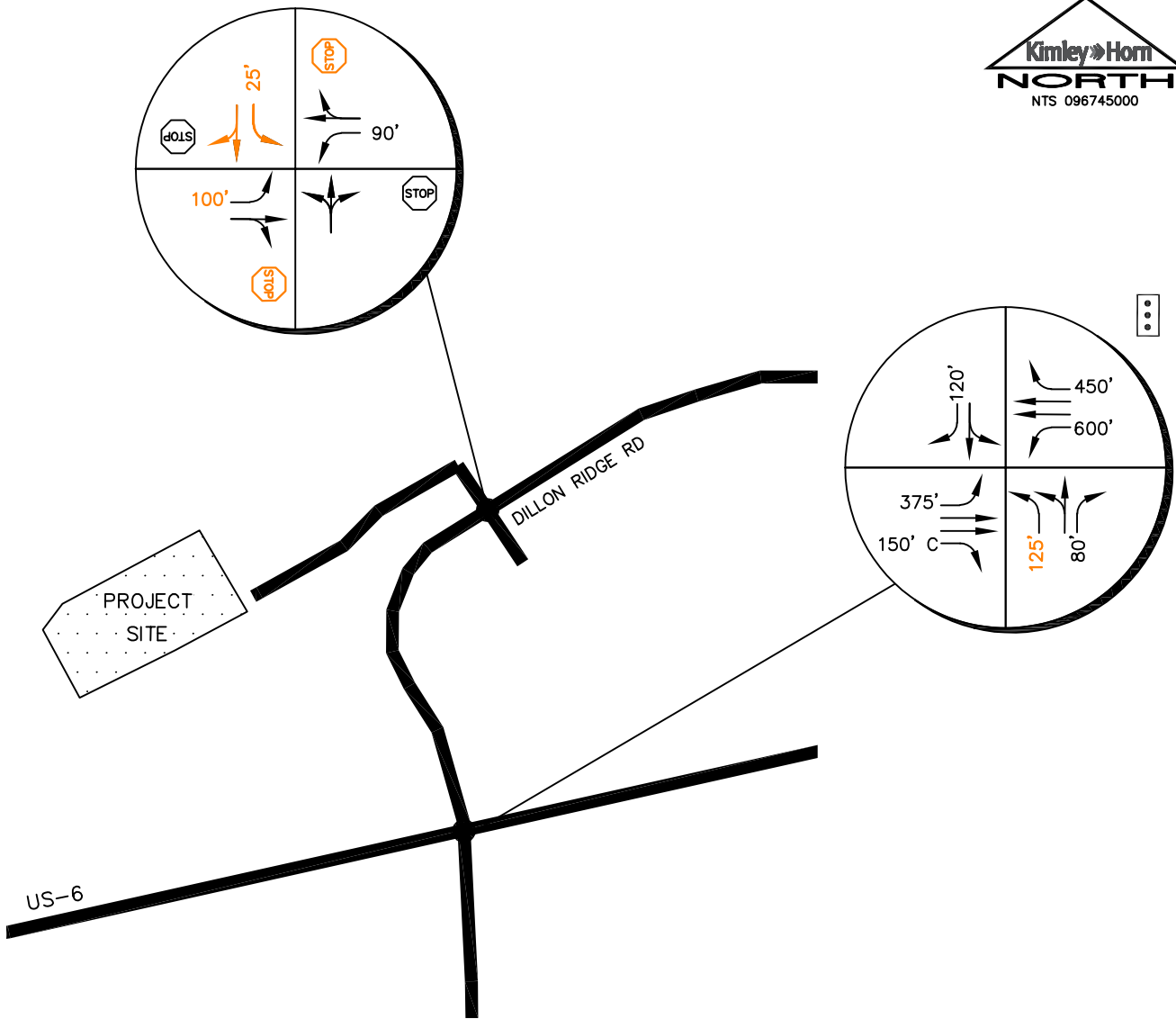

LEGEND	
●	Study Area Key Intersection
⋮	Signalized Intersection
STOP	Stop Controlled Approach
C	Continuous Turn Lane
↪	100' Turn Lane Length (feet)
↪	Improvement

PANERA BREAD DILLON
 RECOMMENDED LANE
 CONFIGURATIONS AND CONTROL

FIGURE 10

6.0 CONCLUSIONS AND RECOMMENDATIONS

Based on the analysis presented in this report, Kimley-Horn believes the proposed Panera Bread in Dillon, Colorado will be successfully incorporated into the existing and future roadway network. The proposed project development and expected traffic volumes resulted in the following recommendations and conclusions:

- It is recommended the intersection of Dillon Ridge Road and the full movement project access be improved to include All-Way Stop Control. R1-1 “STOP” signs should be installed on the eastbound and westbound approaches. In addition, R1-4 “ALL WAY” plaques should be installed underneath all four “STOP” signs. Since this will be a change in control unfamiliar to drivers traveling along Dillon Ridge Road, it is recommended that two red flags be affixed to the top of the new “STOP” signs at 45-degree angles for the new stop control on the eastbound and westbound approaches. These flags should remain for a period of approximately three to six months.
- Additional operational improvements should be considered for the Dillon Ridge Road access intersection by adding striping to the north leg of this access to designate a separate left turn lane. It is believed that the existing driveway is wide enough to designate three lanes with one entering lane and two exiting lanes (a separate left turn and a shared through/right turn lane). This will improve operations of the intersection by processing two vehicles out of the access at the same time under the recommended all way stop control condition.
- With development of the project, it is recommended that the 65-foot eastbound left turn lane at the Dillon Ridge Road full movement access intersection be restriped to include 100 feet of storage length. Incorporation of all-way stop control and striping the southbound approach to include separate left turn and shared through/right turn lanes will help alleviate the queue issues for traffic exiting The Ridge at Dillon retail center. However, it is anticipated that the existing 25-foot throat depth may be exceeded during the Saturday midday peak hour. The all-way stop control will allow traffic to continue moving. If traffic exiting from the Walgreens to the east blocks entering traffic into the

retail center, operations could be improved by closing off the first drive aisle to the Walgreen's site. This could be considered if found to be needed.

- Unrelated to this project, a traffic deficiency exists for the northbound left turn at the US-6 and Dillon Ridge Road/Anemone Trail intersection. Acceptable operations result, however the northbound left turn queue may extend through the Little Dam Street intersection to the south during the peak hours. This is likely why there are separate left turn and a shared left turn/through lane on the northbound approach at the US-6 signalized intersection today to address left turn movements in two lanes. If possible, raised pork chop island channelization for the eastbound right turn lane (deceleration and acceleration) could be added so that the stop bar on the south leg could be moved further north. This would allow for the northbound approach to have an extended queue space on this approach due to the absence of a crosswalk on this leg. If channelizing islands were added to the north side of US-6 as well, the pedestrian crossing distance of the west leg would be significantly reduced, which would improve signal operations, as well as an overall improvement with a true free southbound right turn. These improvements could be considered by CDOT and the Town of Dillon if desired as it is understood that this may impact snow removal operations during the winter.
- By year 2040 the 65-foot eastbound left turn lane at the Dillon Ridge Road and full movement access intersection may need to be restriped to include 100 feet of storage length.
- All on-site and off-site roadway, signing, striping, and signal improvements should be incorporated into the Civil Drawings, and conform to Town of Dillon and Colorado Department of Transportation standards as well as the Manual on Uniform Traffic Control Devices – 2009 Edition (MUTCD).

APPENDICES

APPENDIX A

Intersection Count Sheets



Dillon, CO
 Panera Bread
 AM Peak
 Dillon Ridge Rd Access

File Name : Dillon Ridge Rd Access AM
 Site Code : IPO 358
 Start Date : 7/10/2018
 Page No : 1

Groups Printed- Automobiles

Start Time	Dillon Ridge Rd Eastbound					Dillon Ridge Rd Westbound					Shopping Access Northbound					Walgreens/Shopping Access Southbound					Int. Total
	Left	Thru	Right	U Turn	App. Total	Left	Thru	Right	U Turn	App. Total	Left	Thru	Right	U Turn	App. Total	Left	Thru	Right	U Turn	App. Total	
07:00 AM	0	13	2	0	15	0	15	1	0	16	5	0	0	0	5	0	0	2	0	2	38
07:15 AM	4	19	0	0	23	0	9	0	0	9	0	0	0	0	0	2	0	1	0	3	35
07:30 AM	2	16	5	0	23	1	20	1	0	22	2	0	0	0	2	1	0	1	0	2	49
07:45 AM	4	25	0	0	29	0	23	6	0	29	1	0	0	0	1	1	0	3	0	4	63
Total	10	73	7	0	90	1	67	8	0	76	8	0	0	0	8	4	0	7	0	11	185
08:00 AM	3	20	4	0	27	2	27	1	0	30	1	0	0	0	1	2	0	0	0	2	60
08:15 AM	4	26	7	0	37	2	25	0	0	27	3	1	0	0	4	0	0	4	0	4	72
08:30 AM	4	20	6	0	30	0	26	4	0	30	1	0	1	0	2	0	1	4	0	5	67
08:45 AM	7	27	20	0	54	5	24	2	0	31	4	0	1	0	5	0	0	8	0	8	98
Total	18	93	37	0	148	9	102	7	0	118	9	1	2	0	12	2	1	16	0	19	297
Grand Total	28	166	44	0	238	10	169	15	0	194	17	1	2	0	20	6	1	23	0	30	482
Apprch %	11.8	69.7	18.5	0		5.2	87.1	7.7	0		85	5	10	0		20	3.3	76.7	0		
Total %	5.8	34.4	9.1	0	49.4	2.1	35.1	3.1	0	40.2	3.5	0.2	0.4	0	4.1	1.2	0.2	4.8	0	6.2	

Dillon, CO
Panera Bread
AM Peak
Dillon Ridge Rd Access

File Name : Dillon Ridge Rd Access AM
Site Code : IPO 358
Start Date : 7/10/2018
Page No : 2

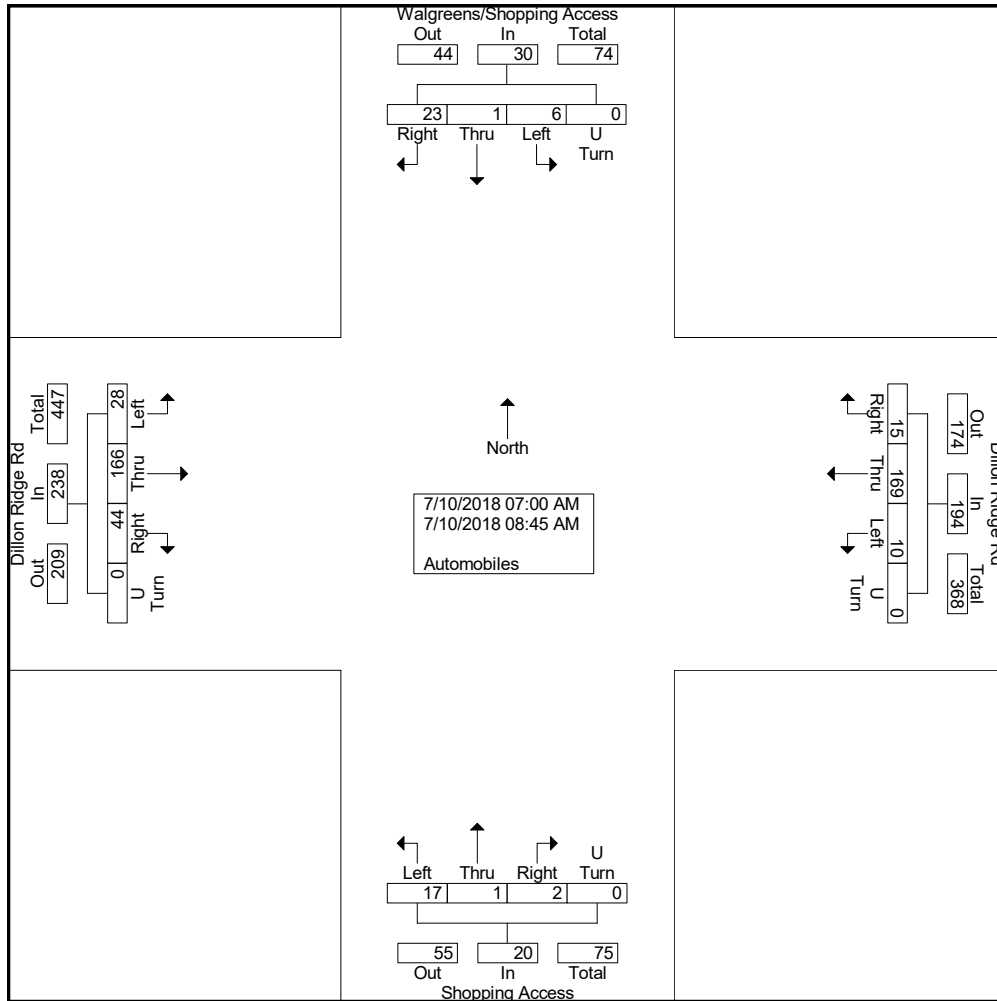

Dillon, CO
Panera Bread
AM Peak
Dillon Ridge Rd Access

File Name : Dillon Ridge Rd Access AM
Site Code : IPO 358
Start Date : 7/10/2018
Page No : 3

Start Time	Dillon Ridge Rd Eastbound					Dillon Ridge Rd Westbound					Shopping Access Northbound					Walgreens/Shopping Access Southbound					Int. Total
	Left	Thru	Right	U Turn	App. Total	Left	Thru	Right	U Turn	App. Total	Left	Thru	Right	U Turn	App. Total	Left	Thru	Right	U Turn	App. Total	
Peak Hour Analysis From 07:00 AM to 08:45 AM - Peak 1 of 1																					
Peak Hour for Entire Intersection Begins at 08:00 AM																					
08:00 AM	3	20	4	0	27	2	27	1	0	30	1	0	0	0	1	2	0	0	0	2	60
08:15 AM	4	26	7	0	37	2	25	0	0	27	3	1	0	0	4	0	0	4	0	4	72
08:30 AM	4	20	6	0	30	0	26	4	0	30	1	0	1	0	2	0	1	4	0	5	67
08:45 AM	7	27	20	0	54	5	24	2	0	31	4	0	1	0	5	0	0	8	0	8	98
Total Volume	18	93	37	0	148	9	102	7	0	118	9	1	2	0	12	2	1	16	0	19	297
% App. Total	12.2	62.8	25	0		7.6	86.4	5.9	0		7.5	8.3	16.7	0		10.5	5.3	84.2	0		
PHF	.643	.861	.463	.000	.685	.450	.944	.438	.000	.952	.563	.250	.500	.000	.600	.250	.250	.500	.000	.594	.758

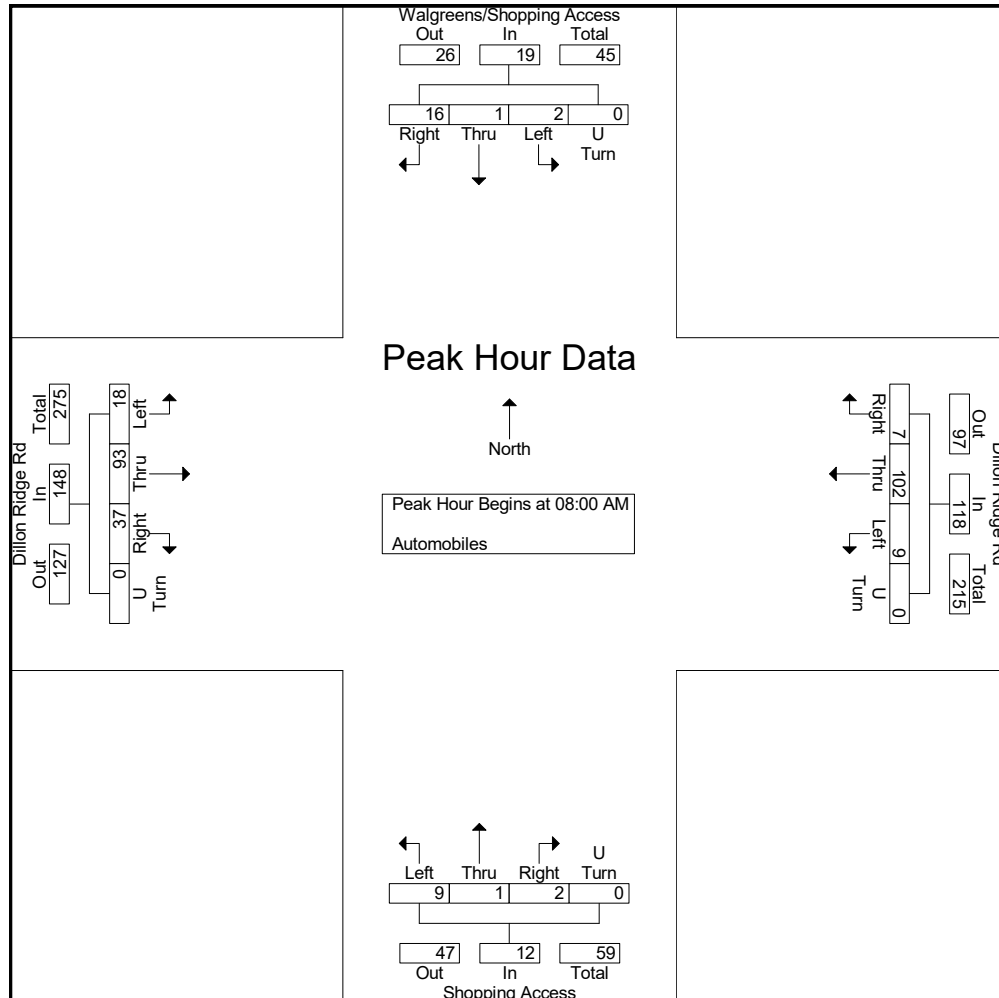



Dillon, CO
 Panera Bread
 PM Peak
 Dillon Ridge Rd Access

File Name : Dillon Ridge Rd Access PM
 Site Code : IPO 358
 Start Date : 7/10/2018
 Page No : 1

Groups Printed- Automobiles

Start Time	Dillon Ridge Rd Eastbound					Dillon Ridge Rd Westbound					Shopping Access Northbound					Walgreens/Shopping Access Southbound					Int. Total
	Left	Thru	Right	U Turn	App. Total	Left	Thru	Right	U Turn	App. Total	Left	Thru	Right	U Turn	App. Total	Left	Thru	Right	U Turn	App. Total	
04:00 PM	20	59	4	0	83	3	45	13	0	61	9	0	1	0	10	11	0	21	0	32	186
04:15 PM	15	62	5	0	82	4	61	10	0	75	8	3	1	0	12	9	0	18	0	27	196
04:30 PM	19	57	6	0	82	1	60	12	0	73	7	0	6	0	13	7	0	22	0	29	197
04:45 PM	20	57	9	0	86	2	65	10	0	77	7	0	3	0	10	3	0	31	0	34	207
Total	74	235	24	0	333	10	231	45	0	286	31	3	11	0	45	30	0	92	0	122	786
05:00 PM	14	60	4	0	78	4	48	11	0	63	6	0	12	0	18	9	0	16	0	25	184
05:15 PM	22	48	12	0	82	5	58	8	0	71	2	1	1	0	4	2	0	25	0	27	184
05:30 PM	19	62	8	0	89	1	47	7	0	55	9	0	5	0	14	8	1	21	0	30	188
05:45 PM	16	72	3	0	91	1	75	13	0	89	4	0	2	0	6	4	0	20	0	24	210
Total	71	242	27	0	340	11	228	39	0	278	21	1	20	0	42	23	1	82	0	106	766
Grand Total	145	477	51	0	673	21	459	84	0	564	52	4	31	0	87	53	1	174	0	228	1552
Approch %	21.5	70.9	7.6	0		3.7	81.4	14.9	0		59.8	4.6	35.6	0		23.2	0.4	76.3	0		
Total %	9.3	30.7	3.3	0	43.4	1.4	29.6	5.4	0	36.3	3.4	0.3	2	0	5.6	3.4	0.1	11.2	0	14.7	

Dillon, CO
Panera Bread
PM Peak
Dillon Ridge Rd Access

File Name : Dillon Ridge Rd Access PM
Site Code : IPO 358
Start Date : 7/10/2018
Page No : 2

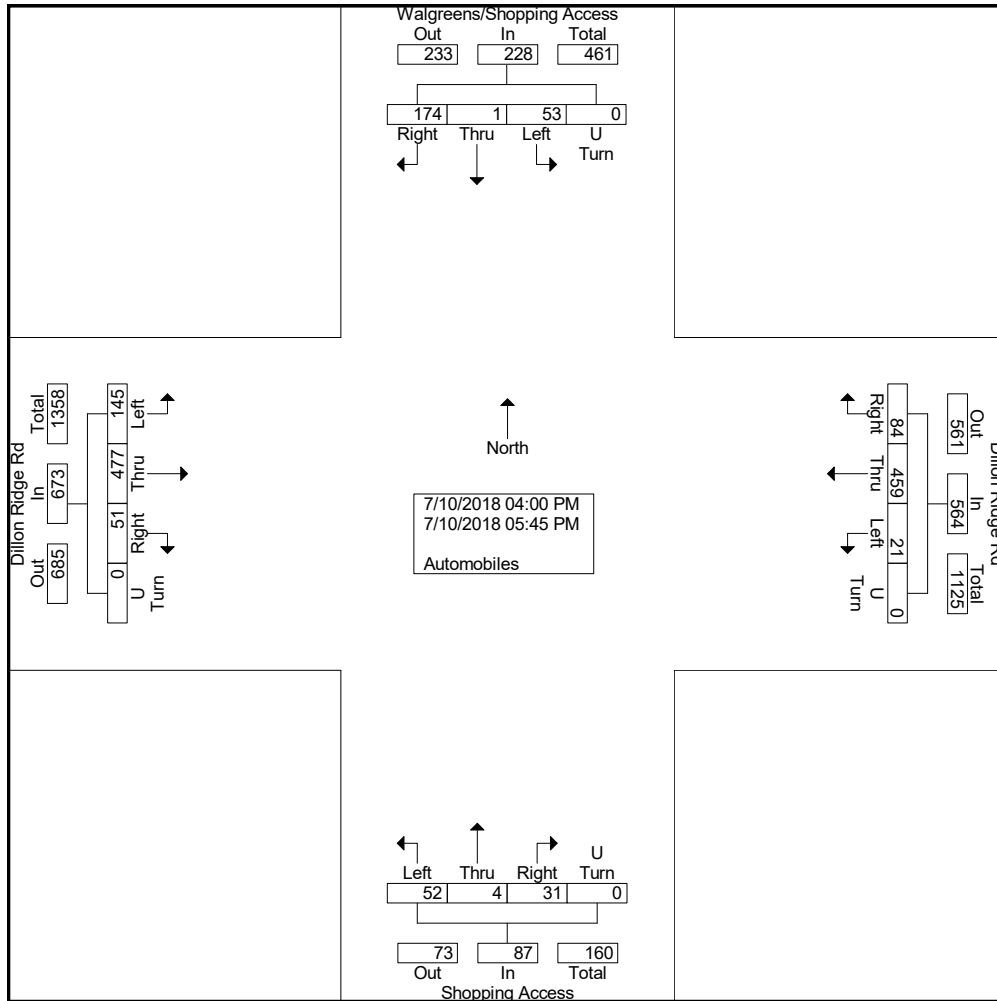

Dillon, CO
Panera Bread
PM Peak
Dillon Ridge Rd Access

File Name : Dillon Ridge Rd Access PM
Site Code : IPO 358
Start Date : 7/10/2018
Page No : 3

Start Time	Dillon Ridge Rd Eastbound					Dillon Ridge Rd Westbound					Shopping Access Northbound					Walgreens/Shopping Access Southbound					Int. Total
	Left	Thru	Right	U Turn	App. Total	Left	Thru	Right	U Turn	App. Total	Left	Thru	Right	U Turn	App. Total	Left	Thru	Right	U Turn	App. Total	
Peak Hour Analysis From 04:00 PM to 05:45 PM - Peak 1 of 1																					
Peak Hour for Entire Intersection Begins at 04:00 PM																					
04:00 PM	20	59	4	0	83	3	45	13	0	61	9	0	1	0	10	11	0	21	0	32	186
04:15 PM	15	62	5	0	82	4	61	10	0	75	8	3	1	0	12	9	0	18	0	27	196
04:30 PM	19	57	6	0	82	1	60	12	0	73	7	0	6	0	13	7	0	22	0	29	197
04:45 PM	20	57	9	0	86	2	65	10	0	77	7	0	3	0	10	3	0	31	0	34	207
Total Volume	74	235	24	0	333	10	231	45	0	286	31	3	11	0	45	30	0	92	0	122	786
% App. Total	22.2	70.6	7.2	0		3.5	80.8	15.7	0		68.9	6.7	24.4	0		24.6	0	75.4	0		
PHF	.925	.948	.667	.000	.968	.625	.888	.865	.000	.929	.861	.250	.458	.000	.865	.682	.000	.742	.000	.897	.949

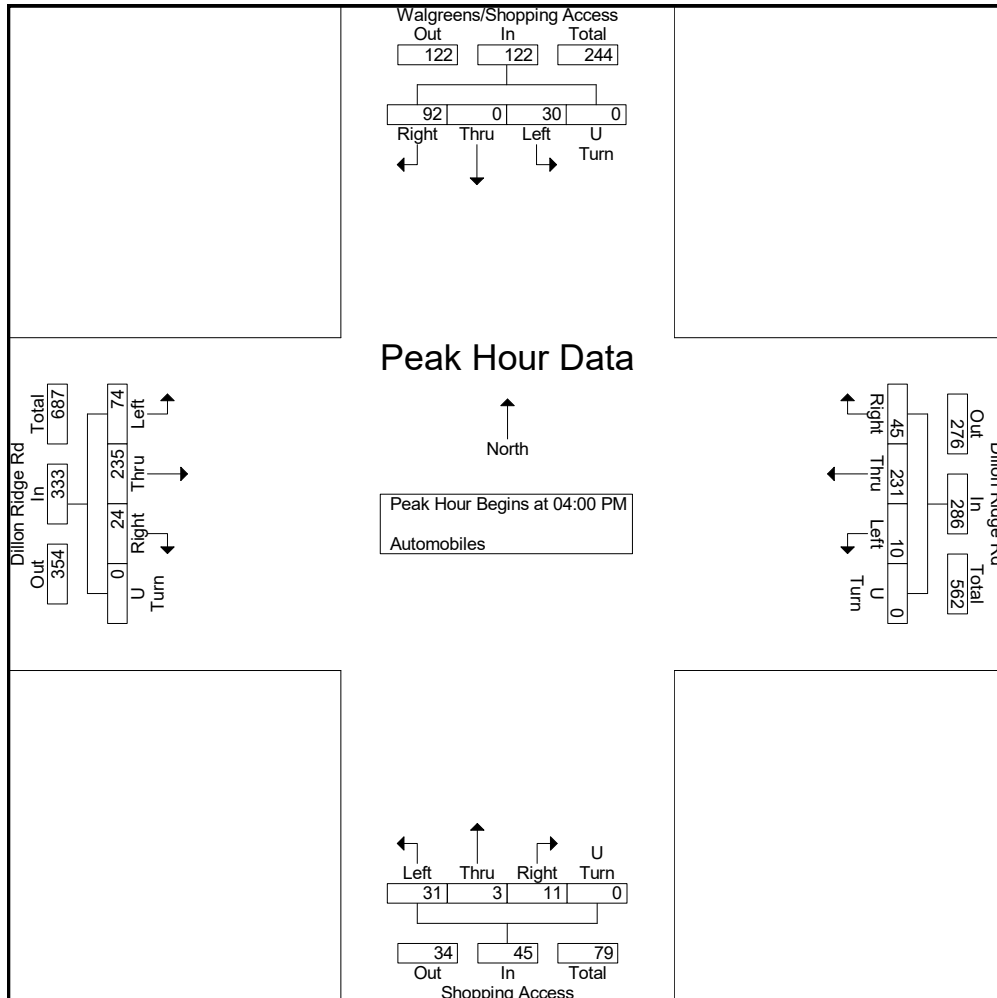



Dillon, CO
 Panera Bread
 Weekend Noon Peak
 Dillon Ridge Rd Access

File Name : Dillon Ridge Rd Access Noon
 Site Code : IPO 367
 Start Date : 9/1/2018
 Page No : 1

Groups Printed- Automobiles

Start Time	Dillon Ridge Rd Eastbound					Dillon Ridge Rd Westbound					Shopping Access Northbound					Walgreens/Shopping Access Southbound					Int. Total
	Left	Thru	Right	U Turn	App. Total	Left	Thru	Right	U Turn	App. Total	Left	Thru	Right	U Turn	App. Total	Left	Thru	Right	U Turn	App. Total	
11:30 AM	25	65	9	0	99	4	65	12	0	81	8	0	3	0	11	3	0	26	0	29	220
11:45 AM	29	62	7	0	98	3	64	14	0	81	8	0	7	0	15	4	0	33	0	37	231
Total	54	127	16	0	197	7	129	26	0	162	16	0	10	0	26	7	0	59	0	66	451
12:00 PM	28	62	3	0	93	4	72	16	0	92	8	0	1	0	9	7	0	27	0	34	228
12:15 PM	45	57	3	0	105	0	62	15	0	77	4	0	6	0	10	3	0	39	0	42	234
12:30 PM	45	63	3	0	111	1	62	10	0	73	4	0	2	0	6	13	0	30	0	43	233
12:45 PM	35	65	5	0	105	1	67	11	0	79	4	1	0	0	5	13	0	43	0	56	245
Total	153	247	14	0	414	6	263	52	0	321	20	1	9	0	30	36	0	139	0	175	940
01:00 PM	42	65	2	0	109	0	70	20	0	90	1	0	1	0	2	10	1	40	0	51	252
01:15 PM	45	75	2	0	122	2	88	9	0	99	1	0	0	0	1	8	0	42	0	50	272
Grand Total	294	514	34	0	842	15	550	107	0	672	38	1	20	0	59	61	1	280	0	342	1915
Approch %	34.9	61	4	0		2.2	81.8	15.9	0		64.4	1.7	33.9	0		17.8	0.3	81.9	0		
Total %	15.4	26.8	1.8	0	44	0.8	28.7	5.6	0	35.1	2	0.1	1	0	3.1	3.2	0.1	14.6	0	17.9	

Dillon, CO
Panera Bread
Weekend Noon Peak
Dillon Ridge Rd Access

File Name : Dillon Ridge Rd Access Noon
Site Code : IPO 367
Start Date : 9/1/2018
Page No : 2

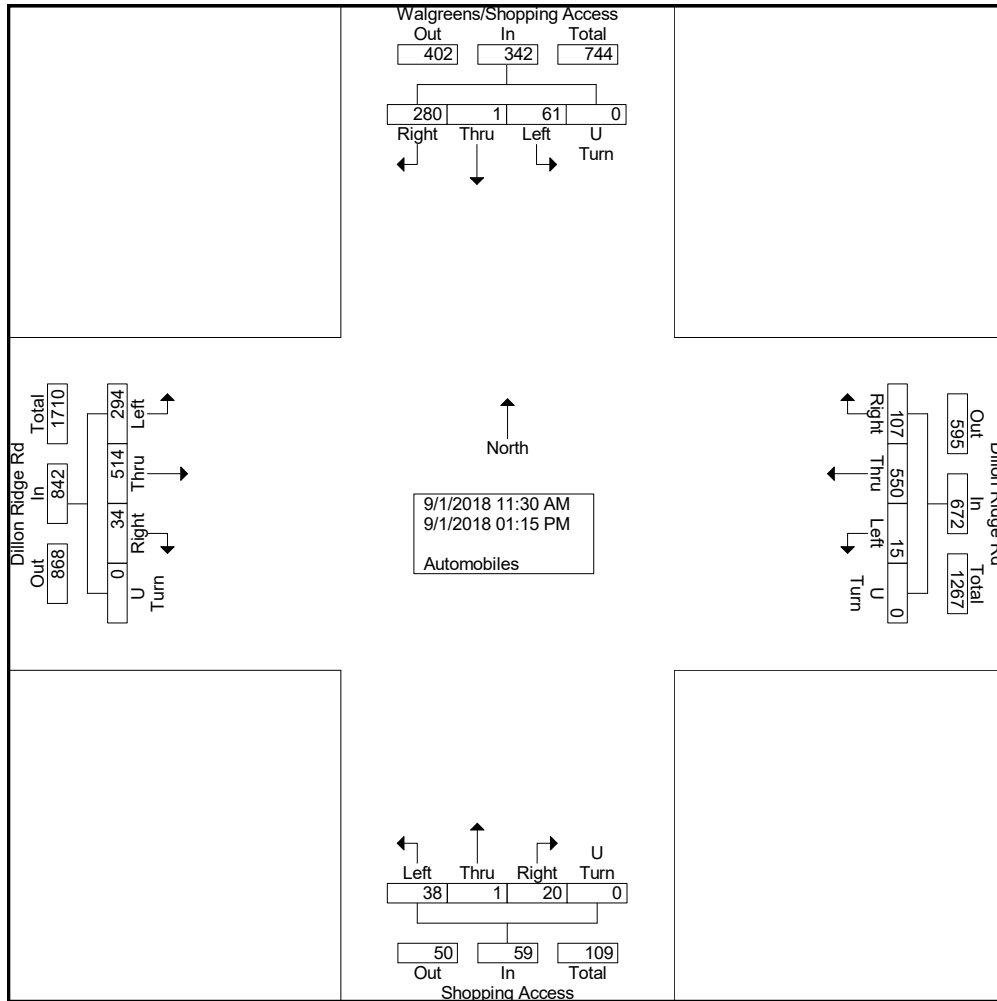

Dillon, CO
Panera Bread
Weekend Noon Peak
Dillon Ridge Rd Access

File Name : Dillon Ridge Rd Access Noon
Site Code : IPO 367
Start Date : 9/1/2018
Page No : 3

Start Time	Dillon Ridge Rd Eastbound					Dillon Ridge Rd Westbound					Shopping Access Northbound					Walgreens/Shopping Access Southbound					Int. Total
	Left	Thru	Right	U Turn	App. Total	Left	Thru	Right	U Turn	App. Total	Left	Thru	Right	U Turn	App. Total	Left	Thru	Right	U Turn	App. Total	
Peak Hour Analysis From 11:30 AM to 01:15 PM - Peak 1 of 1																					
Peak Hour for Entire Intersection Begins at 12:30 PM																					
12:30 PM	45	63	3	0	111	1	62	10	0	73	4	0	2	0	6	13	0	30	0	43	233
12:45 PM	35	65	5	0	105	1	67	11	0	79	4	1	0	0	5	13	0	43	0	56	245
01:00 PM	42	65	2	0	109	0	70	20	0	90	1	0	1	0	2	10	1	40	0	51	252
01:15 PM	45	75	2	0	122	2	88	9	0	99	1	0	0	0	1	8	0	42	0	50	272
Total Volume	167	268	12	0	447	4	287	50	0	341	10	1	3	0	14	44	1	155	0	200	1002
% App. Total	37.4	60	2.7	0		1.2	84.2	14.7	0		71.4	7.1	21.4	0		22	0.5	77.5	0		
PHF	.928	.893	.600	.000	.916	.500	.815	.625	.000	.861	.625	.250	.375	.000	.583	.846	.250	.901	.000	.893	.921

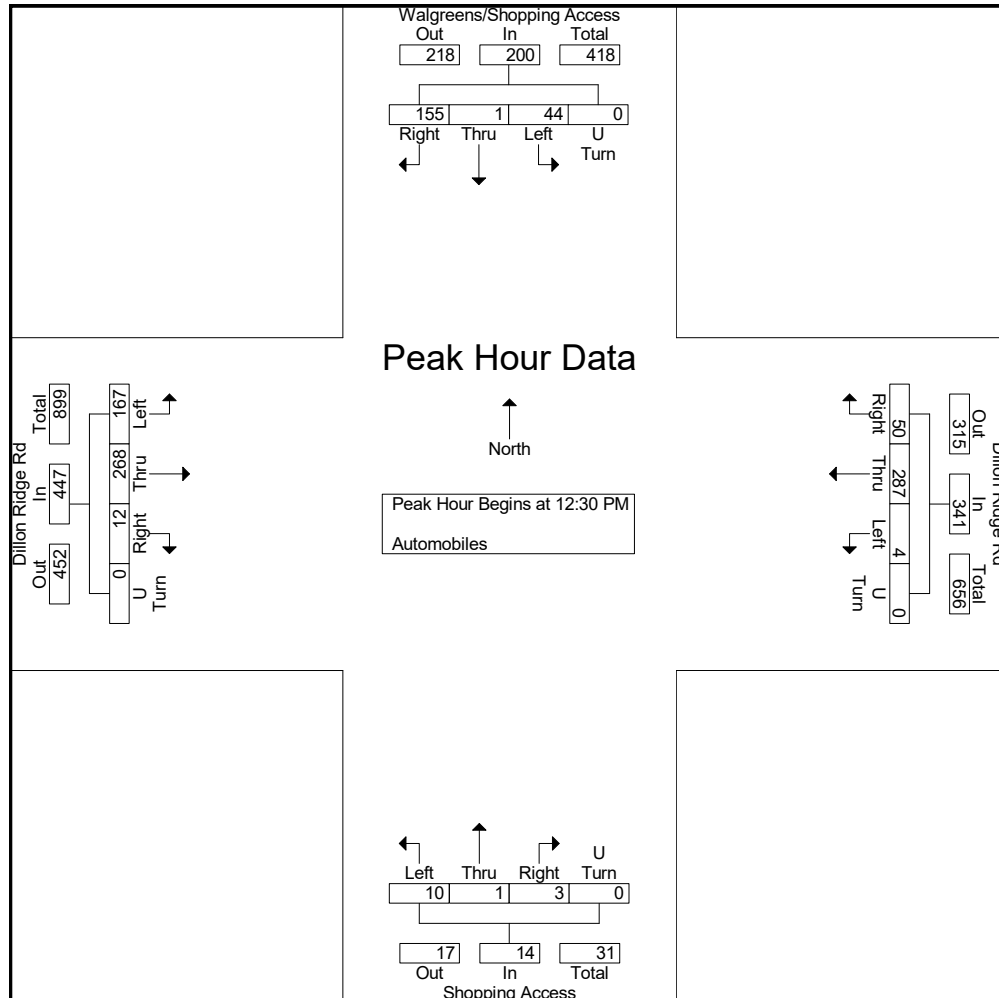



Dillon, CO
 Panera Bread
 AM Peak
 Highway 6 and Dillon Ridge Rd

File Name : Hwy 6 and Dillon Ridge Rd AM
 Site Code : IPO 358
 Start Date : 7/10/2018
 Page No : 1

Groups Printed- Automobiles

Start Time	Highway 6 Eastbound					Highway 6 Westbound					Dillon Ridge Rd Northbound					Dillon Ridge Rd Southbound					Int. Total
	Left	Thru	Right	U Turn	App. Total	Left	Thru	Right	U Turn	App. Total	Left	Thru	Right	U Turn	App. Total	Left	Thru	Right	U Turn	App. Total	
07:00 AM	16	81	1	3	101	0	63	3	0	66	4	0	0	0	4	3	0	18	0	21	192
07:15 AM	27	68	2	2	99	1	77	2	0	80	3	2	0	0	5	0	1	14	0	15	199
07:30 AM	24	112	1	2	139	2	119	3	1	125	8	0	3	0	11	2	1	24	0	27	302
07:45 AM	31	102	2	2	137	5	117	2	1	125	5	0	3	0	8	1	1	30	0	32	302
Total	98	363	6	9	476	8	376	10	2	396	20	2	6	0	28	6	3	86	0	95	995
08:00 AM	23	149	2	0	174	3	137	4	0	144	5	1	2	0	8	2	0	33	0	35	361
08:15 AM	32	132	5	2	171	2	114	8	0	124	5	1	3	0	9	2	0	26	0	28	332
08:30 AM	26	133	5	3	167	5	138	6	0	149	2	0	2	0	4	5	0	29	0	34	354
08:45 AM	48	126	11	2	187	4	129	11	1	145	8	3	3	0	14	6	0	37	0	43	389
Total	129	540	23	7	699	14	518	29	1	562	20	5	10	0	35	15	0	125	0	140	1436
Grand Total	227	903	29	16	1175	22	894	39	3	958	40	7	16	0	63	21	3	211	0	235	2431
Apprch %	19.3	76.9	2.5	1.4		2.3	93.3	4.1	0.3		63.5	11.1	25.4	0		8.9	1.3	89.8	0		
Total %	9.3	37.1	1.2	0.7	48.3	0.9	36.8	1.6	0.1	39.4	1.6	0.3	0.7	0	2.6	0.9	0.1	8.7	0	9.7	

Dillon, CO
Panera Bread
AM Peak
Highway 6 and Dillon Ridge Rd

File Name : Hwy 6 and Dillon Ridge Rd AM
Site Code : IPO 358
Start Date : 7/10/2018
Page No : 2

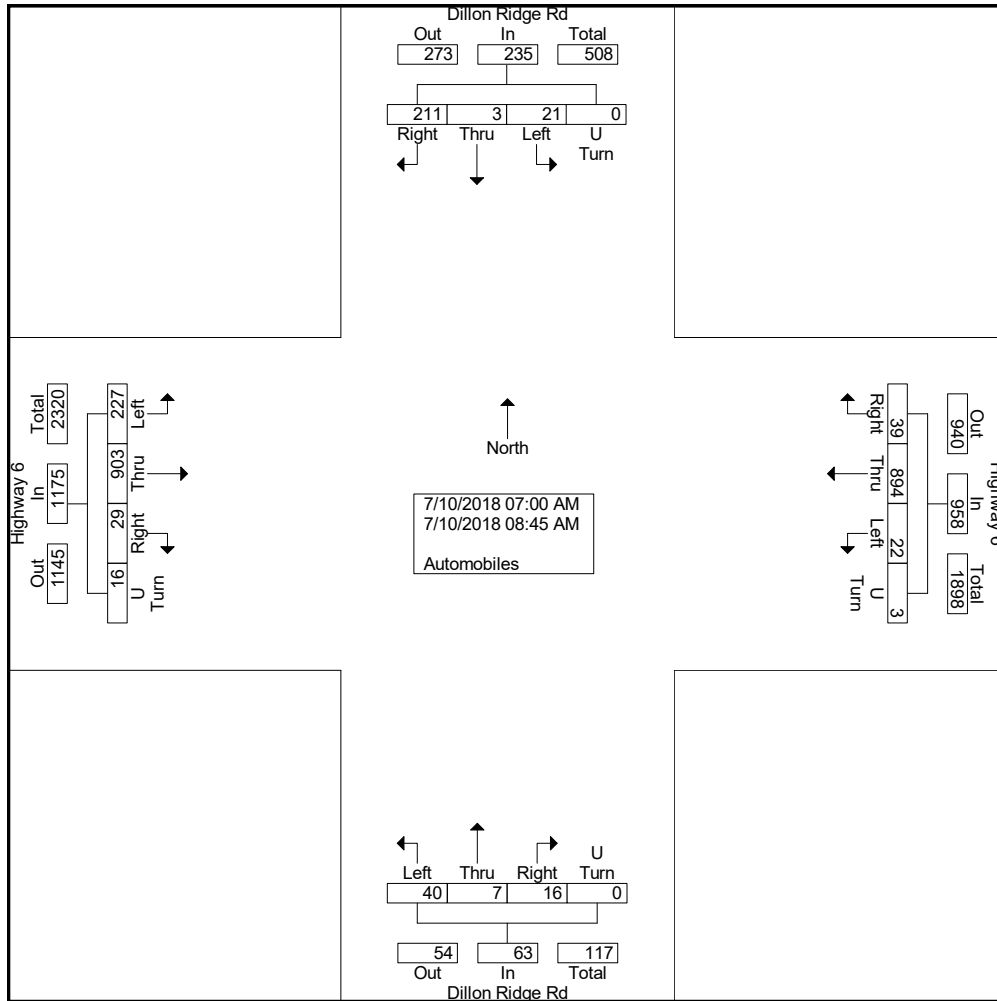

Dillon, CO
Panera Bread
AM Peak
Highway 6 and Dillon Ridge Rd

File Name : Hwy 6 and Dillon Ridge Rd AM
Site Code : IPO 358
Start Date : 7/10/2018
Page No : 3

Start Time	Highway 6 Eastbound					Highway 6 Westbound					Dillon Ridge Rd Northbound					Dillon Ridge Rd Southbound					Int. Total
	Left	Thru	Right	U Turn	App. Total	Left	Thru	Right	U Turn	App. Total	Left	Thru	Right	U Turn	App. Total	Left	Thru	Right	U Turn	App. Total	
Peak Hour Analysis From 07:00 AM to 08:45 AM - Peak 1 of 1																					
Peak Hour for Entire Intersection Begins at 08:00 AM																					
08:00 AM	23	149	2	0	174	3	137	4	0	144	5	1	2	0	8	2	0	33	0	35	361
08:15 AM	32	132	5	2	171	2	114	8	0	124	5	1	3	0	9	2	0	26	0	28	332
08:30 AM	26	133	5	3	167	5	138	6	0	149	2	0	2	0	4	5	0	29	0	34	354
08:45 AM	48	126	11	2	187	4	129	11	1	145	8	3	3	0	14	6	0	37	0	43	389
Total Volume	129	540	23	7	699	14	518	29	1	562	20	5	10	0	35	15	0	125	0	140	1436
% App. Total	18.5	77.3	3.3	1		2.5	92.2	5.2	0.2		57.1	14.3	28.6	0		10.7	0	89.3	0		
PHF	.672	.906	.523	.583	.934	.700	.938	.659	.250	.943	.625	.417	.833	.000	.625	.625	.000	.845	.000	.814	.923

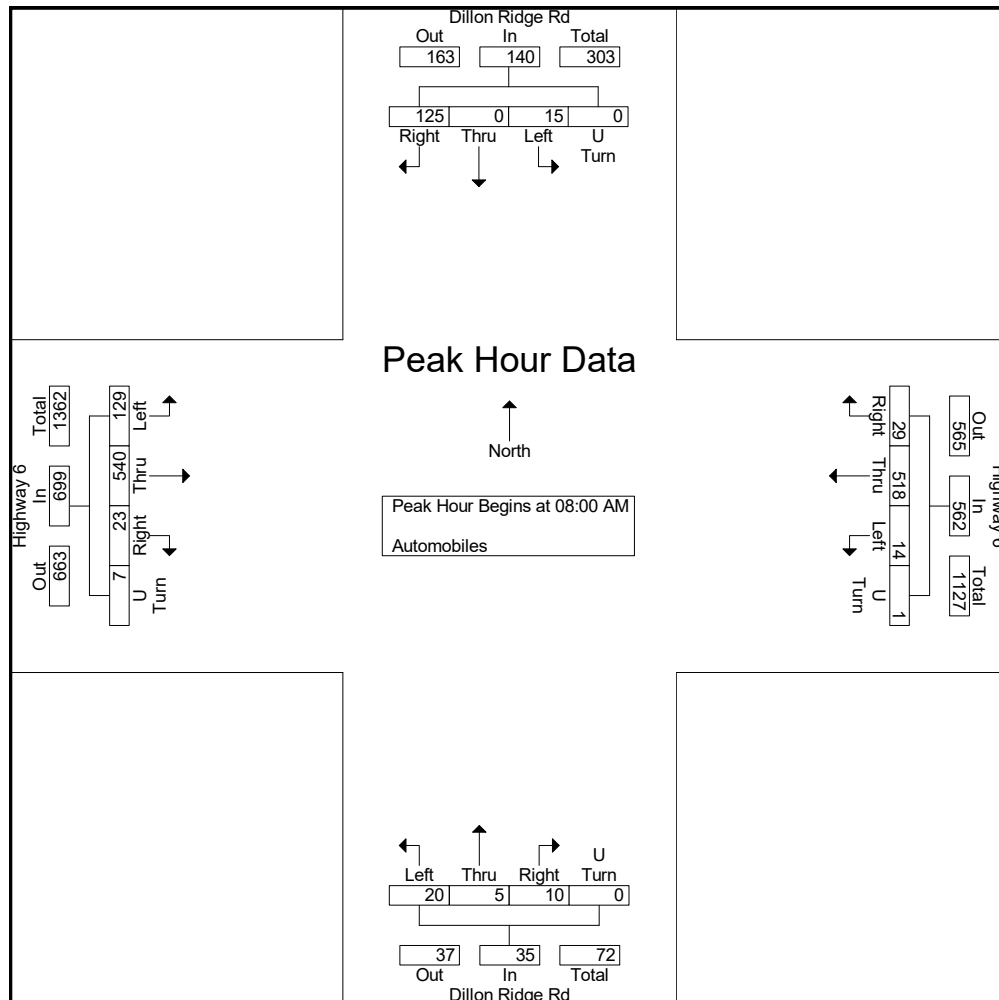



Dillon, CO
 Panera Bread
 PM Peak
 Highway 6 and Dillon Ridge Rd

File Name : Hwy 6 and Dillon Ridge Rd PM
 Site Code : IPO 358
 Start Date : 7/10/2018
 Page No : 1

Groups Printed- Automobiles

Start Time	Highway 6 Eastbound					Highway 6 Westbound					Dillon Ridge Rd Northbound					Dillon Ridge Rd Southbound					Int. Total
	Left	Thru	Right	U Turn	App. Total	Left	Thru	Right	U Turn	App. Total	Left	Thru	Right	U Turn	App. Total	Left	Thru	Right	U Turn	App. Total	
04:00 PM	74	165	11	4	254	10	139	8	1	158	11	4	9	0	24	8	3	67	0	78	514
04:15 PM	65	160	16	0	241	12	176	5	0	193	16	9	9	0	34	9	3	74	0	86	554
04:30 PM	68	170	15	3	256	14	168	10	1	193	11	9	16	0	36	3	3	82	0	88	573
04:45 PM	73	180	11	3	267	17	167	8	0	192	16	8	7	0	31	14	0	82	0	96	586
Total	280	675	53	10	1018	53	650	31	2	736	54	30	41	0	125	34	9	305	0	348	2227
05:00 PM	66	164	7	3	240	5	181	6	0	192	14	5	17	0	36	2	3	75	0	80	548
05:15 PM	68	176	9	2	255	7	160	12	0	179	10	3	12	0	25	2	3	78	0	83	542
05:30 PM	79	175	13	2	269	12	179	9	0	200	11	3	8	0	22	6	0	72	0	78	569
05:45 PM	78	120	12	3	213	11	202	8	0	221	7	3	7	0	17	7	2	93	0	102	553
Total	291	635	41	10	977	35	722	35	0	792	42	14	44	0	100	17	8	318	0	343	2212
Grand Total	571	1310	94	20	1995	88	1372	66	2	1528	96	44	85	0	225	51	17	623	0	691	4439
Apprch %	28.6	65.7	4.7	1		5.8	89.8	4.3	0.1		42.7	19.6	37.8	0		7.4	2.5	90.2	0		
Total %	12.9	29.5	2.1	0.5	44.9	2	30.9	1.5	0	34.4	2.2	1	1.9	0	5.1	1.1	0.4	14	0	15.6	

Dillon, CO
Panera Bread
PM Peak
Highway 6 and Dillon Ridge Rd

File Name : Hwy 6 and Dillon Ridge Rd PM
Site Code : IPO 358
Start Date : 7/10/2018
Page No : 2

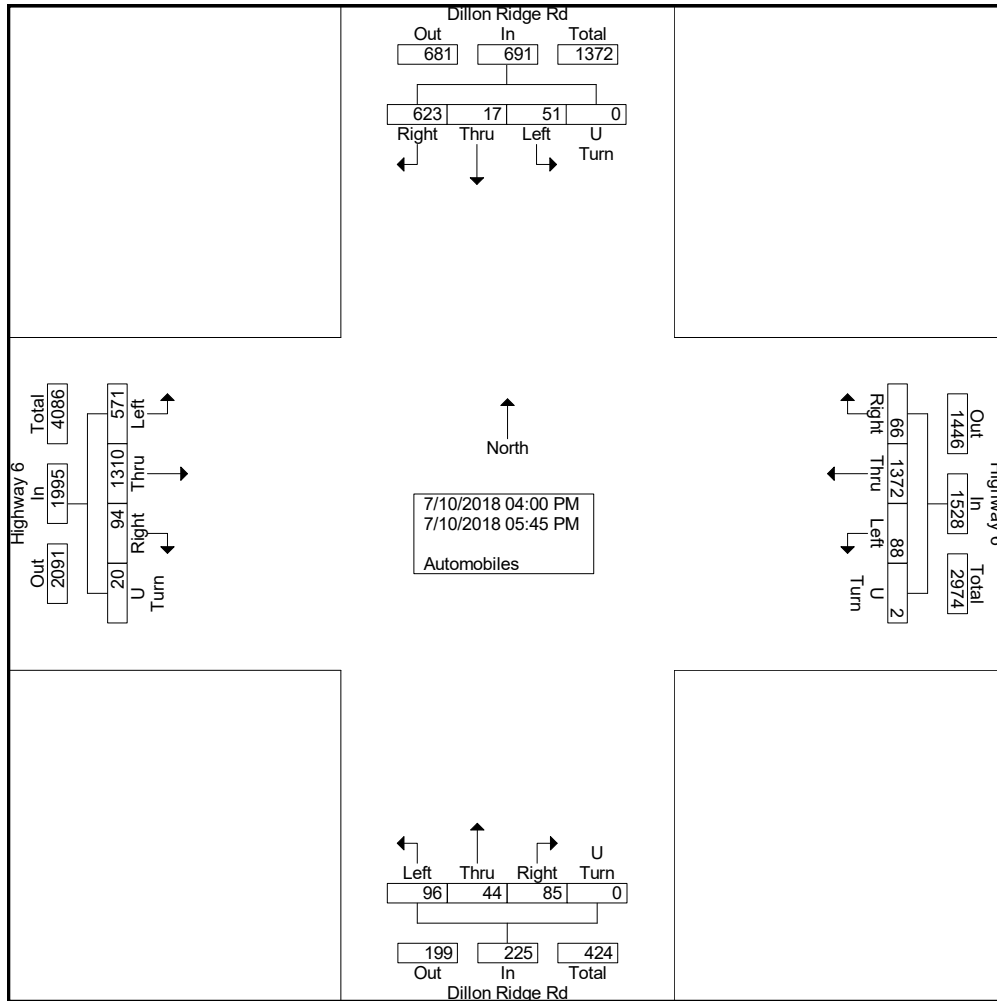

Dillon, CO
Panera Bread
PM Peak
Highway 6 and Dillon Ridge Rd

File Name : Hwy 6 and Dillon Ridge Rd PM
Site Code : IPO 358
Start Date : 7/10/2018
Page No : 3

Start Time	Highway 6 Eastbound					Highway 6 Westbound					Dillon Ridge Rd Northbound					Dillon Ridge Rd Southbound					Int. Total
	Left	Thru	Right	U Turn	App. Total	Left	Thru	Right	U Turn	App. Total	Left	Thru	Right	U Turn	App. Total	Left	Thru	Right	U Turn	App. Total	
Peak Hour Analysis From 04:00 PM to 05:45 PM - Peak 1 of 1																					
Peak Hour for Entire Intersection Begins at 04:15 PM																					
04:15 PM	65	160	16	0	241	12	176	5	0	193	16	9	9	0	34	9	3	74	0	86	554
04:30 PM	68	170	15	3	256	14	168	10	1	193	11	9	16	0	36	3	3	82	0	88	573
04:45 PM	73	180	11	3	267	17	167	8	0	192	16	8	7	0	31	14	0	82	0	96	586
05:00 PM	66	164	7	3	240	5	181	6	0	192	14	5	17	0	36	2	3	75	0	80	548
Total Volume	272	674	49	9	1004	48	692	29	1	770	57	31	49	0	137	28	9	313	0	350	2261
% App. Total	27.1	67.1	4.9	0.9		6.2	89.9	3.8	0.1		41.6	22.6	35.8	0		8	2.6	89.4	0		
PHF	.932	.936	.766	.750	.940	.706	.956	.725	.250	.997	.891	.861	.721	.000	.951	.500	.750	.954	.000	.911	.965

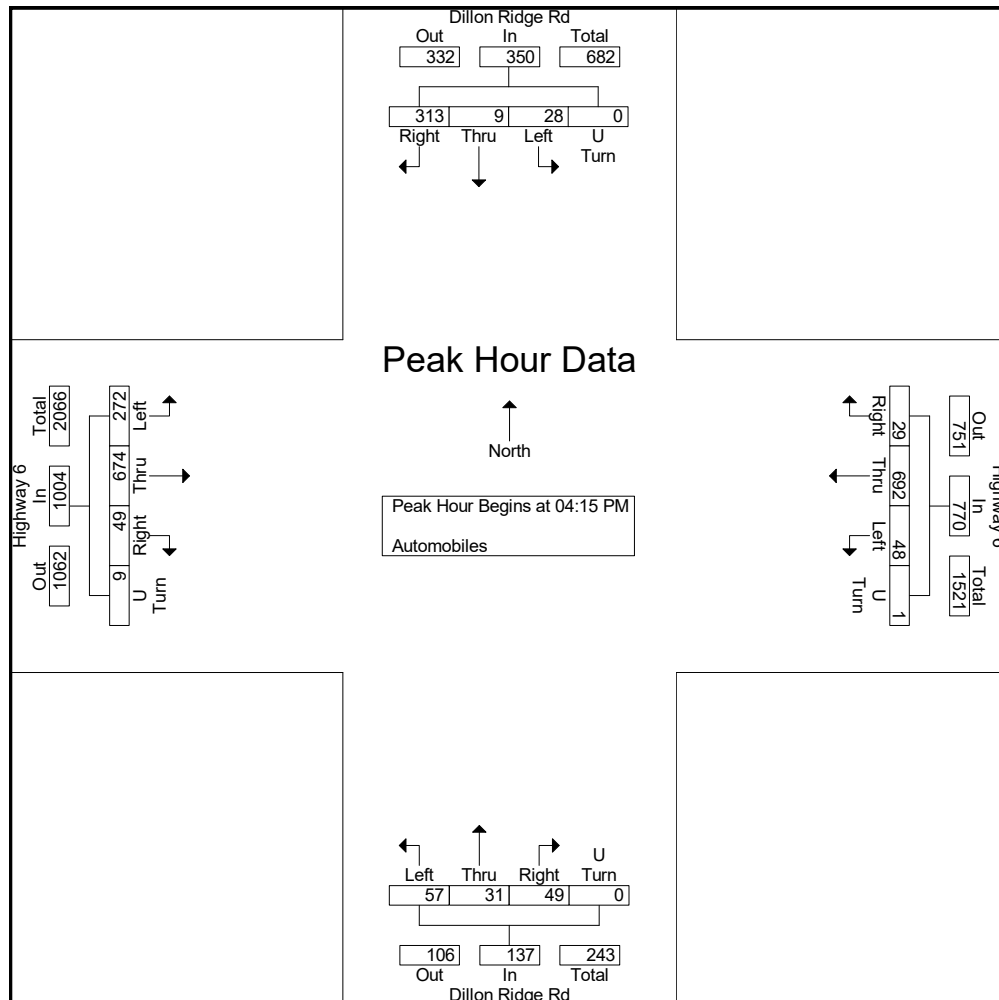



Dillon, CO
 Panera Bread
 Weekend Noon Peak
 Highway 6 and Dillon Ridge Rd

File Name : Hwy 6 and Dillon Ridge Rd Noon
 Site Code : IPO 367
 Start Date : 9/1/2018
 Page No : 1

Groups Printed- Automobiles

Start Time	Highway 6 Eastbound					Highway 6 Westbound					Dillon Ridge Rd Northbound					Dillon Ridge Rd Southbound					Int. Total
	Left	Thru	Right	U Turn	App. Total	Left	Thru	Right	U Turn	App. Total	Left	Thru	Right	U Turn	App. Total	Left	Thru	Right	U Turn	App. Total	
11:30 AM	94	200	23	1	318	15	219	13	1	248	13	2	9	1	25	10	1	92	0	103	694
11:45 AM	92	205	13	2	312	17	207	8	3	235	20	1	16	0	37	14	8	94	0	116	700
Total	186	405	36	3	630	32	426	21	4	483	33	3	25	1	62	24	9	186	0	219	1394
12:00 PM	88	204	16	1	309	15	197	12	1	225	18	1	13	0	32	12	1	86	0	99	665
12:15 PM	101	256	19	2	378	16	202	9	0	227	20	2	16	0	38	14	1	102	0	117	760
12:30 PM	97	229	16	7	349	8	212	10	0	230	29	4	8	0	41	9	5	93	0	107	727
12:45 PM	94	206	17	4	321	14	163	9	0	186	19	4	21	0	44	15	7	98	0	120	671
Total	380	895	68	14	1357	53	774	40	1	868	86	11	58	0	155	50	14	379	0	443	2823
01:00 PM	101	223	19	4	347	8	205	10	4	227	18	3	12	0	33	13	1	96	0	110	717
01:15 PM	110	254	25	3	392	12	170	13	2	197	21	3	19	0	43	8	7	126	0	141	773
Grand Total	777	1777	148	24	2726	105	1575	84	11	1775	158	20	114	1	293	95	31	787	0	913	5707
Approch %	28.5	65.2	5.4	0.9		5.9	88.7	4.7	0.6		53.9	6.8	38.9	0.3		10.4	3.4	86.2	0		
Total %	13.6	31.1	2.6	0.4	47.8	1.8	27.6	1.5	0.2	31.1	2.8	0.4	2	0	5.1	1.7	0.5	13.8	0	16	

Dillon, CO
Panera Bread
Weekend Noon Peak
Highway 6 and Dillon Ridge Rd

File Name : Hwy 6 and Dillon Ridge Rd Noon
Site Code : IPO 367
Start Date : 9/1/2018
Page No : 2

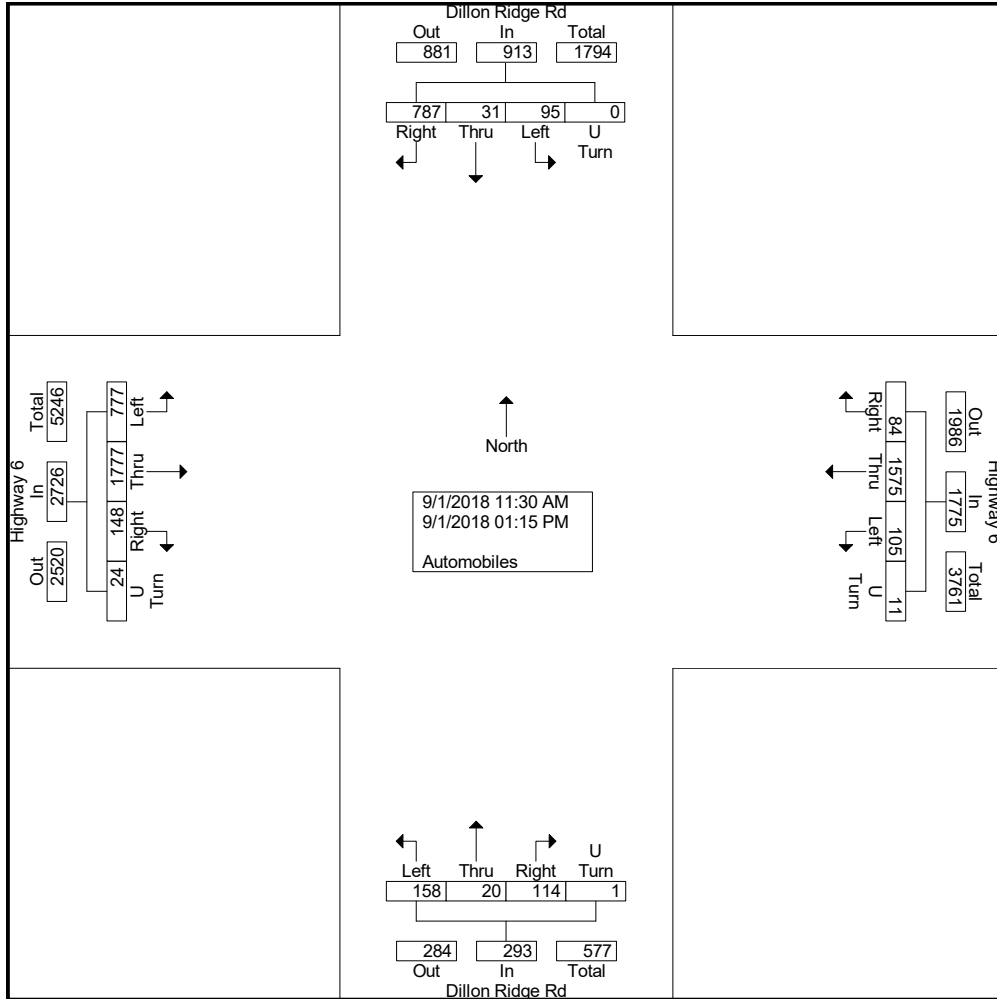

Dillon, CO
Panera Bread
Weekend Noon Peak
Highway 6 and Dillon Ridge Rd

File Name : Hwy 6 and Dillon Ridge Rd Noon
Site Code : IPO 367
Start Date : 9/1/2018
Page No : 3

Start Time	Highway 6 Eastbound					Highway 6 Westbound					Dillon Ridge Rd Northbound					Dillon Ridge Rd Southbound					Int. Total
	Left	Thru	Right	U Turn	App. Total	Left	Thru	Right	U Turn	App. Total	Left	Thru	Right	U Turn	App. Total	Left	Thru	Right	U Turn	App. Total	
Peak Hour Analysis From 11:30 AM to 01:15 PM - Peak 1 of 1																					
Peak Hour for Entire Intersection Begins at 12:30 PM																					
12:30 PM	97	229	16	7	349	8	212	10	0	230	29	4	8	0	41	9	5	93	0	107	727
12:45 PM	94	206	17	4	321	14	163	9	0	186	19	4	21	0	44	15	7	98	0	120	671
01:00 PM	101	223	19	4	347	8	205	10	4	227	18	3	12	0	33	13	1	96	0	110	717
01:15 PM	110	254	25	3	392	12	170	13	2	197	21	3	19	0	43	8	7	126	0	141	773
Total Volume	402	912	77	18	1409	42	750	42	6	840	87	14	60	0	161	45	20	413	0	478	2888
% App. Total	28.5	64.7	5.5	1.3		5	89.3	5	0.7		54	8.7	37.3	0		9.4	4.2	86.4	0		
PHF	.914	.898	.770	.643	.899	.750	.884	.808	.375	.913	.750	.875	.714	.000	.915	.750	.714	.819	.000	.848	.934

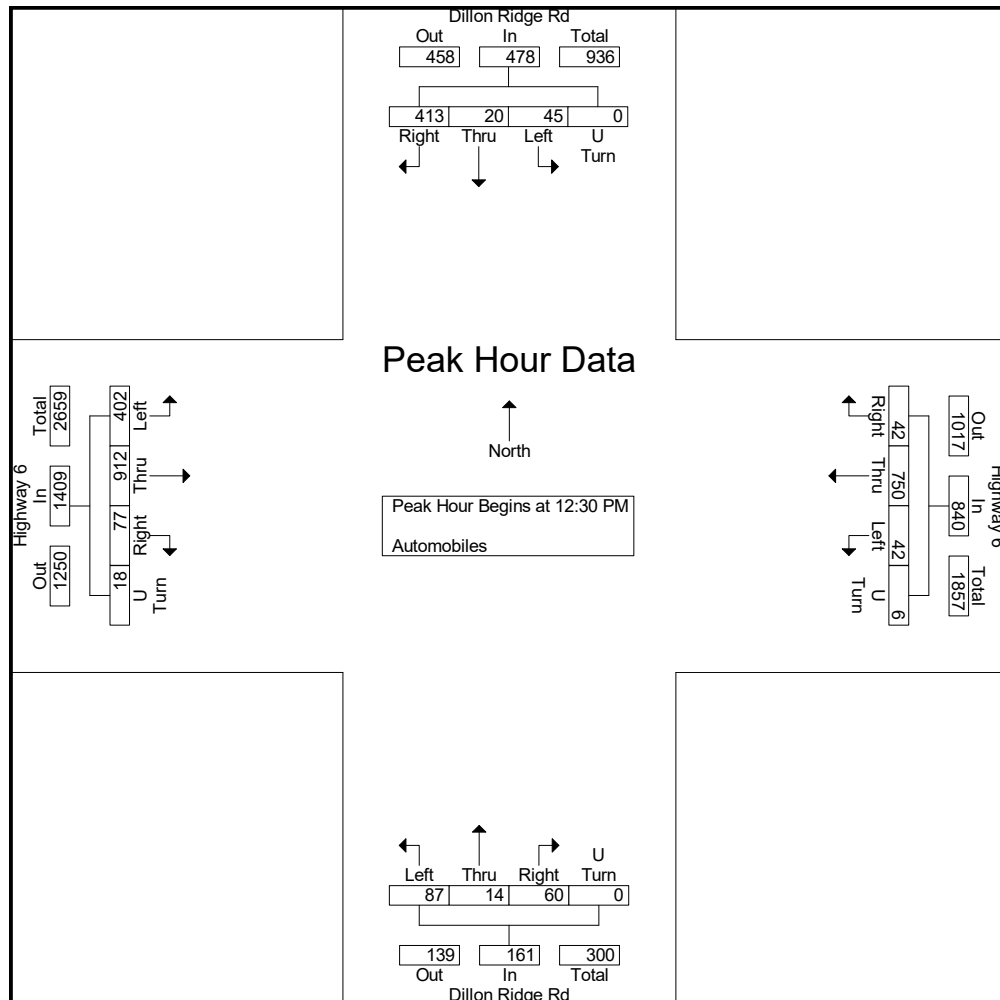

APPENDIX B

CDOT Annual Traffic Data

Panera Bread Dillon Traffic Projections:

ROUTE	REFPT	ENDREFPT	LENGTH	AADT	AADTYR	YR20FACTOR	DHV	LOCATION
006F	208.659	208.95	0.263	26000	2016	1.26	10.5	ON SH 6 SE/O I-70 SILVERTHORNE
006F	208.95	209.844	0.923	18000	2016	1.19	12.5	ON SH 6 W/O DILLON DAM RD CR 7 DILLON
006F	209.844	210.662	0.838	13000	2016	1.24	14	ON SH 6 E/O EVERGREEN RD LAKE DILLON DR DILLON

APPENDIX C

Trip Generation Worksheets

Project Panera Bread Dillon
 Subject Trip Generation for Fast-Food Restaurant with Drive-Through Window
 Designed by ACK Date August 29, 2018 Job No. 096745000
 Checked by _____ Date _____ Sheet No. 1 of 1

TRIP GENERATION MANUAL TECHNIQUES

ITE Trip Generation Manual 10th Edition, Average Rate Equations

Land Use Code - Fast Food Restaurant With Drive-Through Window (934)

Independant Variable - 1000 Square Feet Gross Floor Area (X)

Gross Floor Area = **4,500** Square Feet

X = 4.500

T = Average Vehicle Trip Ends

Peak Hour of Adjacent Street Traffic, One Hour Between 7 and 9 a.m. (900 Series page 158)

Average Weekday		Directional Distribution:	51% ent.	49% exit.
T = 40.19 (X)		T = 181	Average Vehicle Trip Ends	
T = 40.19 *	4.500	92 entering	89	exiting
		92 + 89 =	181	

Peak Hour of Adjacent Street Traffic, One Hour Between 4 and 6 p.m. (900 Series page 159)

Average Weekday		Directional Distribution:	52% ent.	48% exit.
T = 32.67 (X)		T = 147	Average Vehicle Trip Ends	
T = 32.67 *	4.500	76 entering	71	exiting
		76 + 71 =	147	

Weekday (900 Series page 157)

Average Weekday		Directional Distribution:	50% entering,	50% exiting
T = 470.95 (X)		T = 2120	Average Vehicle Trip Ends	
T = 470.95 *	4.500	1060 entering	1060	exiting
		1060 + 1060 =	2120	

Saturday Peak Hour of Generator (900 Series page 163)

		Directional Distribution:	51% ent.	49% exit.
T = 54.86 (X)		T = 247	Average Vehicle Trip Ends	
T = 54.86 *	4.500	126 entering	121	exiting
		126 + 121 =	247	

Non Pass-By Trip Volumes (Per ITE Trip Generation Handbook, 3rd Edition September 2017)

AM Peak Hour =	51%	Non-Pass By	PM Peak Hour =	50%	Non-Pass By
	IN	Out	Total		
AM Peak	47	45	92		
PM Peak	38	36	74		
Daily	530	530	1060		PM Peak Hour Rate Applied to Daily

Pass-By Trip Volumes (Per ITE Trip Generation Handbook, 3rd Edition September 2017)

AM Peak Hour =	49%	Pass By	PM Peak Hour =	50%	Pass By
	IN	Out	Total		
AM Peak	45	44	89		
PM Peak	38	36	74		
Daily	530	530	1060		PM Peak Hour Rate Applied to Daily

APPENDIX D

Intersection Analysis Worksheets

Intersection												
Int Delay, s/veh	2.5											
Movement	EBL	EBT	EBR	WBL	WBT	WBR	NBL	NBT	NBR	SBL	SBT	SBR
Lane Configurations	↶	↷		↶	↷			↕			↕	
Traffic Vol, veh/h	18	93	37	9	102	7	9	1	2	2	1	16
Future Vol, veh/h	18	93	37	9	102	7	9	1	2	2	1	16
Conflicting Peds, #/hr	0	0	0	0	0	0	0	0	0	0	0	0
Sign Control	Free	Free	Free	Free	Free	Free	Stop	Stop	Stop	Stop	Stop	Stop
RT Channelized	-	-	None	-	-	None	-	-	None	-	-	None
Storage Length	65	-	-	90	-	-	-	-	-	-	-	-
Veh in Median Storage, #	-	0	-	-	0	-	-	0	-	-	0	-
Grade, %	-	0	-	-	0	-	-	0	-	-	0	-
Peak Hour Factor	64	86	46	45	94	44	56	25	50	25	25	50
Heavy Vehicles, %	2	2	2	2	2	2	2	2	2	2	2	2
Mvmt Flow	28	108	80	20	109	16	16	4	4	8	4	32

Major/Minor	Major1			Major2			Minor1			Minor2		
Conflicting Flow All	125	0	0	188	0	0	379	369	148	365	401	117
Stage 1	-	-	-	-	-	-	204	204	-	157	157	-
Stage 2	-	-	-	-	-	-	175	165	-	208	244	-
Critical Hdwy	4.12	-	-	4.12	-	-	7.12	6.52	6.22	7.12	6.52	6.22
Critical Hdwy Stg 1	-	-	-	-	-	-	6.12	5.52	-	6.12	5.52	-
Critical Hdwy Stg 2	-	-	-	-	-	-	6.12	5.52	-	6.12	5.52	-
Follow-up Hdwy	2.218	-	-	2.218	-	-	3.518	4.018	3.318	3.518	4.018	3.318
Pot Cap-1 Maneuver	1462	-	-	1386	-	-	579	560	899	591	538	935
Stage 1	-	-	-	-	-	-	798	733	-	845	768	-
Stage 2	-	-	-	-	-	-	827	762	-	794	704	-
Platoon blocked, %	-	-	-	-	-	-	-	-	-	-	-	-
Mov Cap-1 Maneuver	1462	-	-	1386	-	-	542	542	899	570	520	935
Mov Cap-2 Maneuver	-	-	-	-	-	-	542	542	-	570	520	-
Stage 1	-	-	-	-	-	-	783	719	-	829	757	-
Stage 2	-	-	-	-	-	-	783	751	-	771	691	-

Approach	EB			WB			NB			SB		
HCM Control Delay, s	1			1.1			11.5			9.9		
HCM LOS							B			A		

Minor Lane/Major Mvmt	NBLn1	EBL	EBT	EBR	WBL	WBT	WBR	SBLn1
Capacity (veh/h)	580	1462	-	-	1386	-	-	786
HCM Lane V/C Ratio	0.042	0.019	-	-	0.014	-	-	0.056
HCM Control Delay (s)	11.5	7.5	-	-	7.6	-	-	9.9
HCM Lane LOS	B	A	-	-	A	-	-	A
HCM 95th %tile Q(veh)	0.1	0.1	-	-	0	-	-	0.2

Intersection												
Int Delay, s/veh	5											
Movement	EBL	EBT	EBR	WBL	WBT	WBR	NBL	NBT	NBR	SBL	SBT	SBR
Lane Configurations	↶	↷		↶	↷			↕			↕	
Traffic Vol, veh/h	74	235	24	10	231	45	31	3	11	30	0	92
Future Vol, veh/h	74	235	24	10	231	45	31	3	11	30	0	92
Conflicting Peds, #/hr	0	0	0	0	0	0	0	0	0	0	0	0
Sign Control	Free	Free	Free	Free	Free	Free	Stop	Stop	Stop	Stop	Stop	Stop
RT Channelized	-	-	None	-	-	None	-	-	None	-	-	None
Storage Length	65	-	-	90	-	-	-	-	-	-	-	-
Veh in Median Storage, #	-	0	-	-	0	-	-	0	-	-	0	-
Grade, %	-	0	-	-	0	-	-	0	-	-	0	-
Peak Hour Factor	93	95	67	62	89	86	86	25	46	68	92	74
Heavy Vehicles, %	2	2	2	2	2	2	2	2	2	2	2	2
Mvmt Flow	80	247	36	16	260	52	36	12	24	44	0	124

Major/Minor	Major1			Major2			Minor1			Minor2		
Conflicting Flow All	312	0	0	283	0	0	805	769	265	761	761	286
Stage 1	-	-	-	-	-	-	425	425	-	318	318	-
Stage 2	-	-	-	-	-	-	380	344	-	443	443	-
Critical Hdwy	4.12	-	-	4.12	-	-	7.12	6.52	6.22	7.12	6.52	6.22
Critical Hdwy Stg 1	-	-	-	-	-	-	6.12	5.52	-	6.12	5.52	-
Critical Hdwy Stg 2	-	-	-	-	-	-	6.12	5.52	-	6.12	5.52	-
Follow-up Hdwy	2.218	-	-	2.218	-	-	3.518	4.018	3.318	3.518	4.018	3.318
Pot Cap-1 Maneuver	1248	-	-	1279	-	-	301	332	774	322	335	753
Stage 1	-	-	-	-	-	-	607	586	-	693	654	-
Stage 2	-	-	-	-	-	-	642	637	-	594	576	-
Platoon blocked, %	-	-	-	-	-	-	-	-	-	-	-	-
Mov Cap-1 Maneuver	1248	-	-	1279	-	-	237	307	774	285	310	753
Mov Cap-2 Maneuver	-	-	-	-	-	-	237	307	-	285	310	-
Stage 1	-	-	-	-	-	-	568	548	-	649	645	-
Stage 2	-	-	-	-	-	-	529	629	-	527	539	-

Approach	EB			WB			NB			SB		
HCM Control Delay, s	1.8			0.4			19.3			15		
HCM LOS							C			C		

Minor Lane/Major Mvmt	NBLn1	EBL	EBT	EBR	WBL	WBT	WBR	SBLn1
Capacity (veh/h)	324	1248	-	-	1279	-	-	527
HCM Lane V/C Ratio	0.222	0.064	-	-	0.013	-	-	0.32
HCM Control Delay (s)	19.3	8.1	-	-	7.9	-	-	15
HCM Lane LOS	C	A	-	-	A	-	-	C
HCM 95th %tile Q(veh)	0.8	0.2	-	-	0	-	-	1.4

Intersection												
Int Delay, s/veh	7.4											
Movement	EBL	EBT	EBR	WBL	WBT	WBR	NBL	NBT	NBR	SBL	SBT	SBR
Lane Configurations	↶	↷		↶	↷			↕			↕	
Traffic Vol, veh/h	167	268	12	4	287	50	10	1	3	44	1	155
Future Vol, veh/h	167	268	12	4	287	50	10	1	3	44	1	155
Conflicting Peds, #/hr	0	0	0	0	0	0	0	0	0	0	0	0
Sign Control	Free	Free	Free	Free	Free	Free	Stop	Stop	Stop	Stop	Stop	Stop
RT Channelized	-	-	None	-	-	None	-	-	None	-	-	None
Storage Length	65	-	-	90	-	-	-	-	-	-	-	-
Veh in Median Storage, #	-	0	-	-	0	-	-	0	-	-	0	-
Grade, %	-	0	-	-	0	-	-	0	-	-	0	-
Peak Hour Factor	93	89	60	50	81	62	62	25	38	85	25	90
Heavy Vehicles, %	2	2	2	2	2	2	2	2	2	2	2	2
Mvmt Flow	180	301	20	8	354	81	16	4	8	52	4	172

Major/Minor	Major1			Major2			Minor1			Minor2		
Conflicting Flow All	435	0	0	321	0	0	1170	1122	311	1088	1092	395
Stage 1	-	-	-	-	-	-	671	671	-	411	411	-
Stage 2	-	-	-	-	-	-	499	451	-	677	681	-
Critical Hdwy	4.12	-	-	4.12	-	-	7.12	6.52	6.22	7.12	6.52	6.22
Critical Hdwy Stg 1	-	-	-	-	-	-	6.12	5.52	-	6.12	5.52	-
Critical Hdwy Stg 2	-	-	-	-	-	-	6.12	5.52	-	6.12	5.52	-
Follow-up Hdwy	2.218	-	-	2.218	-	-	3.518	4.018	3.318	3.518	4.018	3.318
Pot Cap-1 Maneuver	1125	-	-	1239	-	-	170	206	729	193	215	654
Stage 1	-	-	-	-	-	-	446	455	-	618	595	-
Stage 2	-	-	-	-	-	-	554	571	-	443	450	-
Platoon blocked, %	-	-	-	-	-	-	-	-	-	-	-	-
Mov Cap-1 Maneuver	1125	-	-	1239	-	-	107	172	729	164	180	654
Mov Cap-2 Maneuver	-	-	-	-	-	-	107	172	-	164	180	-
Stage 1	-	-	-	-	-	-	375	382	-	519	591	-
Stage 2	-	-	-	-	-	-	403	568	-	364	378	-

Approach	EB			WB			NB			SB		
HCM Control Delay, s	3.2			0.1			34			27.8		
HCM LOS							D			D		

Minor Lane/Major Mvmt	NBLn1	EBL	EBT	EBR	WBL	WBT	WBR	SBLn1
Capacity (veh/h)	152	1125	-	-	1239	-	-	379
HCM Lane V/C Ratio	0.184	0.16	-	-	0.006	-	-	0.602
HCM Control Delay (s)	34	8.8	-	-	7.9	-	-	27.8
HCM Lane LOS	D	A	-	-	A	-	-	D
HCM 95th %tile Q(veh)	0.7	0.6	-	-	0	-	-	3.8

Intersection												
Int Delay, s/veh	2.5											
Movement	EBL	EBT	EBR	WBL	WBT	WBR	NBL	NBT	NBR	SBL	SBT	SBR
Lane Configurations	↶	↷		↶	↷			↕			↕	
Traffic Vol, veh/h	18	93	37	9	102	7	9	1	2	2	1	16
Future Vol, veh/h	18	93	37	9	102	7	9	1	2	2	1	16
Conflicting Peds, #/hr	0	0	0	0	0	0	0	0	0	0	0	0
Sign Control	Free	Free	Free	Free	Free	Free	Stop	Stop	Stop	Stop	Stop	Stop
RT Channelized	-	-	None	-	-	None	-	-	None	-	-	None
Storage Length	65	-	-	90	-	-	-	-	-	-	-	-
Veh in Median Storage, #	-	0	-	-	0	-	-	0	-	-	0	-
Grade, %	-	0	-	-	0	-	-	0	-	-	0	-
Peak Hour Factor	64	86	46	45	94	44	56	25	50	25	25	50
Heavy Vehicles, %	2	2	2	2	2	2	2	2	2	2	2	2
Mvmt Flow	28	108	80	20	109	16	16	4	4	8	4	32

Major/Minor	Major1			Major2			Minor1			Minor2		
Conflicting Flow All	125	0	0	188	0	0	379	369	148	365	401	117
Stage 1	-	-	-	-	-	-	204	204	-	157	157	-
Stage 2	-	-	-	-	-	-	175	165	-	208	244	-
Critical Hdwy	4.12	-	-	4.12	-	-	7.12	6.52	6.22	7.12	6.52	6.22
Critical Hdwy Stg 1	-	-	-	-	-	-	6.12	5.52	-	6.12	5.52	-
Critical Hdwy Stg 2	-	-	-	-	-	-	6.12	5.52	-	6.12	5.52	-
Follow-up Hdwy	2.218	-	-	2.218	-	-	3.518	4.018	3.318	3.518	4.018	3.318
Pot Cap-1 Maneuver	1462	-	-	1386	-	-	579	560	899	591	538	935
Stage 1	-	-	-	-	-	-	798	733	-	845	768	-
Stage 2	-	-	-	-	-	-	827	762	-	794	704	-
Platoon blocked, %	-	-	-	-	-	-	-	-	-	-	-	-
Mov Cap-1 Maneuver	1462	-	-	1386	-	-	542	542	899	570	520	935
Mov Cap-2 Maneuver	-	-	-	-	-	-	542	542	-	570	520	-
Stage 1	-	-	-	-	-	-	783	719	-	829	757	-
Stage 2	-	-	-	-	-	-	783	751	-	771	691	-

Approach	EB			WB			NB			SB		
HCM Control Delay, s	1			1.1			11.5			9.9		
HCM LOS							B			A		

Minor Lane/Major Mvmt	NBLn1	EBL	EBT	EBR	WBL	WBT	WBR	SBLn1
Capacity (veh/h)	580	1462	-	-	1386	-	-	786
HCM Lane V/C Ratio	0.042	0.019	-	-	0.014	-	-	0.056
HCM Control Delay (s)	11.5	7.5	-	-	7.6	-	-	9.9
HCM Lane LOS	B	A	-	-	A	-	-	A
HCM 95th %tile Q(veh)	0.1	0.1	-	-	0	-	-	0.2

Intersection												
Int Delay, s/veh	5											
Movement	EBL	EBT	EBR	WBL	WBT	WBR	NBL	NBT	NBR	SBL	SBT	SBR
Lane Configurations	↶	↷		↶	↷			↕			↕	
Traffic Vol, veh/h	74	235	24	10	231	45	31	3	11	30	0	92
Future Vol, veh/h	74	235	24	10	231	45	31	3	11	30	0	92
Conflicting Peds, #/hr	0	0	0	0	0	0	0	0	0	0	0	0
Sign Control	Free	Free	Free	Free	Free	Free	Stop	Stop	Stop	Stop	Stop	Stop
RT Channelized	-	-	None	-	-	None	-	-	None	-	-	None
Storage Length	65	-	-	90	-	-	-	-	-	-	-	-
Veh in Median Storage, #	-	0	-	-	0	-	-	0	-	-	0	-
Grade, %	-	0	-	-	0	-	-	0	-	-	0	-
Peak Hour Factor	93	95	67	62	89	86	86	25	46	68	92	74
Heavy Vehicles, %	2	2	2	2	2	2	2	2	2	2	2	2
Mvmt Flow	80	247	36	16	260	52	36	12	24	44	0	124

Major/Minor	Major1			Major2			Minor1			Minor2		
Conflicting Flow All	312	0	0	283	0	0	805	769	265	761	761	286
Stage 1	-	-	-	-	-	-	425	425	-	318	318	-
Stage 2	-	-	-	-	-	-	380	344	-	443	443	-
Critical Hdwy	4.12	-	-	4.12	-	-	7.12	6.52	6.22	7.12	6.52	6.22
Critical Hdwy Stg 1	-	-	-	-	-	-	6.12	5.52	-	6.12	5.52	-
Critical Hdwy Stg 2	-	-	-	-	-	-	6.12	5.52	-	6.12	5.52	-
Follow-up Hdwy	2.218	-	-	2.218	-	-	3.518	4.018	3.318	3.518	4.018	3.318
Pot Cap-1 Maneuver	1248	-	-	1279	-	-	301	332	774	322	335	753
Stage 1	-	-	-	-	-	-	607	586	-	693	654	-
Stage 2	-	-	-	-	-	-	642	637	-	594	576	-
Platoon blocked, %	-	-	-	-	-	-	-	-	-	-	-	-
Mov Cap-1 Maneuver	1248	-	-	1279	-	-	237	307	774	285	310	753
Mov Cap-2 Maneuver	-	-	-	-	-	-	237	307	-	285	310	-
Stage 1	-	-	-	-	-	-	568	548	-	649	645	-
Stage 2	-	-	-	-	-	-	529	629	-	527	539	-

Approach	EB	WB	NB	SB
HCM Control Delay, s	1.8	0.4	19.3	15
HCM LOS			C	C

Minor Lane/Major Mvmt	NBLn1	EBL	EBT	EBR	WBL	WBT	WBR	SBLn1
Capacity (veh/h)	324	1248	-	-	1279	-	-	527
HCM Lane V/C Ratio	0.222	0.064	-	-	0.013	-	-	0.32
HCM Control Delay (s)	19.3	8.1	-	-	7.9	-	-	15
HCM Lane LOS	C	A	-	-	A	-	-	C
HCM 95th %tile Q(veh)	0.8	0.2	-	-	0	-	-	1.4

Intersection												
Int Delay, s/veh	7.4											
Movement	EBL	EBT	EBR	WBL	WBT	WBR	NBL	NBT	NBR	SBL	SBT	SBR
Lane Configurations												
Traffic Vol, veh/h	167	268	12	4	287	50	10	1	3	44	1	155
Future Vol, veh/h	167	268	12	4	287	50	10	1	3	44	1	155
Conflicting Peds, #/hr	0	0	0	0	0	0	0	0	0	0	0	0
Sign Control	Free	Free	Free	Free	Free	Free	Stop	Stop	Stop	Stop	Stop	Stop
RT Channelized	-	-	None	-	-	None	-	-	None	-	-	None
Storage Length	65	-	-	90	-	-	-	-	-	-	-	-
Veh in Median Storage, #	-	0	-	-	0	-	-	0	-	-	0	-
Grade, %	-	0	-	-	0	-	-	0	-	-	0	-
Peak Hour Factor	93	89	60	50	81	62	62	25	38	85	25	90
Heavy Vehicles, %	2	2	2	2	2	2	2	2	2	2	2	2
Mvmt Flow	180	301	20	8	354	81	16	4	8	52	4	172

Major/Minor	Major1			Major2			Minor1			Minor2		
Conflicting Flow All	435	0	0	321	0	0	1170	1122	311	1088	1092	395
Stage 1	-	-	-	-	-	-	671	671	-	411	411	-
Stage 2	-	-	-	-	-	-	499	451	-	677	681	-
Critical Hdwy	4.12	-	-	4.12	-	-	7.12	6.52	6.22	7.12	6.52	6.22
Critical Hdwy Stg 1	-	-	-	-	-	-	6.12	5.52	-	6.12	5.52	-
Critical Hdwy Stg 2	-	-	-	-	-	-	6.12	5.52	-	6.12	5.52	-
Follow-up Hdwy	2.218	-	-	2.218	-	-	3.518	4.018	3.318	3.518	4.018	3.318
Pot Cap-1 Maneuver	1125	-	-	1239	-	-	170	206	729	193	215	654
Stage 1	-	-	-	-	-	-	446	455	-	618	595	-
Stage 2	-	-	-	-	-	-	554	571	-	443	450	-
Platoon blocked, %	-	-	-	-	-	-	-	-	-	-	-	-
Mov Cap-1 Maneuver	1125	-	-	1239	-	-	107	172	729	164	180	654
Mov Cap-2 Maneuver	-	-	-	-	-	-	107	172	-	164	180	-
Stage 1	-	-	-	-	-	-	375	382	-	519	591	-
Stage 2	-	-	-	-	-	-	403	568	-	364	378	-

Approach	EB			WB			NB			SB		
HCM Control Delay, s	3.2			0.1			34			27.8		
HCM LOS							D			D		

Minor Lane/Major Mvmt	NBLn1	EBL	EBT	EBR	WBL	WBT	WBR	SBLn1
Capacity (veh/h)	152	1125	-	-	1239	-	-	379
HCM Lane V/C Ratio	0.184	0.16	-	-	0.006	-	-	0.602
HCM Control Delay (s)	34	8.8	-	-	7.9	-	-	27.8
HCM Lane LOS	D	A	-	-	A	-	-	D
HCM 95th %tile Q(veh)	0.7	0.6	-	-	0	-	-	3.8

Intersection												
Int Delay, s/veh	6.6											
Movement	EBL	EBT	EBR	WBL	WBT	WBR	NBL	NBT	NBR	SBL	SBT	SBR
Lane Configurations	↔	↔		↔	↔			↔			↔	↔
Traffic Vol, veh/h	96	93	37	9	102	21	9	1	2	15	1	92
Future Vol, veh/h	96	93	37	9	102	21	9	1	2	15	1	92
Conflicting Peds, #/hr	0	0	0	0	0	0	0	0	0	0	0	0
Sign Control	Free	Free	Free	Free	Free	Free	Stop	Stop	Stop	Stop	Stop	Stop
RT Channelized	-	-	None	-	-	None	-	-	None	-	-	None
Storage Length	65	-	-	90	-	-	-	-	-	-	-	-
Veh in Median Storage, #	-	0	-	-	0	-	-	0	-	-	0	-
Grade, %	-	0	-	-	0	-	-	0	-	-	0	-
Peak Hour Factor	64	86	46	45	94	44	56	25	50	25	25	50
Heavy Vehicles, %	2	2	2	2	2	2	2	2	2	2	2	2
Mvmt Flow	150	108	80	20	109	48	16	4	4	60	4	184

Major/Minor	Major1			Major2			Minor1			Minor2		
Conflicting Flow All	157	0	0	188	0	0	715	645	148	625	661	133
Stage 1	-	-	-	-	-	-	448	448	-	173	173	-
Stage 2	-	-	-	-	-	-	267	197	-	452	488	-
Critical Hdwy	4.12	-	-	4.12	-	-	7.12	6.52	6.22	7.12	6.52	6.22
Critical Hdwy Stg 1	-	-	-	-	-	-	6.12	5.52	-	6.12	5.52	-
Critical Hdwy Stg 2	-	-	-	-	-	-	6.12	5.52	-	6.12	5.52	-
Follow-up Hdwy	2.218	-	-	2.218	-	-	3.518	4.018	3.318	3.518	4.018	3.318
Pot Cap-1 Maneuver	1423	-	-	1386	-	-	346	391	899	397	383	916
Stage 1	-	-	-	-	-	-	590	573	-	829	756	-
Stage 2	-	-	-	-	-	-	738	738	-	587	550	-
Platoon blocked, %	-	-	-	-	-	-	-	-	-	-	-	-
Mov Cap-1 Maneuver	1423	-	-	1386	-	-	249	345	899	356	338	916
Mov Cap-2 Maneuver	-	-	-	-	-	-	249	345	-	356	338	-
Stage 1	-	-	-	-	-	-	528	513	-	742	745	-
Stage 2	-	-	-	-	-	-	578	728	-	519	492	-

Approach	EB			WB			NB			SB		
HCM Control Delay, s	3.5			0.9			18.1			13.9		
HCM LOS							C			B		

Minor Lane/Major Mvmt	NBLn1	EBL	EBT	EBR	WBL	WBT	WBR	SBLn1
Capacity (veh/h)	299	1423	-	-	1386	-	-	650
HCM Lane V/C Ratio	0.081	0.105	-	-	0.014	-	-	0.382
HCM Control Delay (s)	18.1	7.8	-	-	7.6	-	-	13.9
HCM Lane LOS		C	A	-	-	A	-	B
HCM 95th %tile Q(veh)	0.3	0.4	-	-	0	-	-	1.8

Intersection												
Int Delay, s/veh	8.3											
Movement	EBL	EBT	EBR	WBL	WBT	WBR	NBL	NBT	NBR	SBL	SBT	SBR
Lane Configurations	↔	↔		↔	↔			↔			↔	↔
Traffic Vol, veh/h	139	235	24	10	231	56	31	3	11	41	0	152
Future Vol, veh/h	139	235	24	10	231	56	31	3	11	41	0	152
Conflicting Peds, #/hr	0	0	0	0	0	0	0	0	0	0	0	0
Sign Control	Free	Free	Free	Free	Free	Free	Stop	Stop	Stop	Stop	Stop	Stop
RT Channelized	-	-	None	-	-	None	-	-	None	-	-	None
Storage Length	65	-	-	90	-	-	-	-	-	-	-	-
Veh in Median Storage, #	-	0	-	-	0	-	-	0	-	-	0	-
Grade, %	-	0	-	-	0	-	-	0	-	-	0	-
Peak Hour Factor	93	95	67	62	89	86	86	25	46	68	92	74
Heavy Vehicles, %	2	2	2	2	2	2	2	2	2	2	2	2
Mvmt Flow	149	247	36	16	260	65	36	12	24	60	0	205

Major/Minor	Major1			Major2			Minor1			Minor2		
Conflicting Flow All	325	0	0	283	0	0	990	920	265	906	906	293
Stage 1	-	-	-	-	-	-	563	563	-	325	325	-
Stage 2	-	-	-	-	-	-	427	357	-	581	581	-
Critical Hdwy	4.12	-	-	4.12	-	-	7.12	6.52	6.22	7.12	6.52	6.22
Critical Hdwy Stg 1	-	-	-	-	-	-	6.12	5.52	-	6.12	5.52	-
Critical Hdwy Stg 2	-	-	-	-	-	-	6.12	5.52	-	6.12	5.52	-
Follow-up Hdwy	2.218	-	-	2.218	-	-	3.518	4.018	3.318	3.518	4.018	3.318
Pot Cap-1 Maneuver	1235	-	-	1279	-	-	225	271	774	257	276	746
Stage 1	-	-	-	-	-	-	511	509	-	687	649	-
Stage 2	-	-	-	-	-	-	606	628	-	499	500	-
Platoon blocked, %	-	-	-	-	-	-	-	-	-	-	-	-
Mov Cap-1 Maneuver	1235	-	-	1279	-	-	147	235	774	215	240	746
Mov Cap-2 Maneuver	-	-	-	-	-	-	147	235	-	215	240	-
Stage 1	-	-	-	-	-	-	449	447	-	604	641	-
Stage 2	-	-	-	-	-	-	434	620	-	414	440	-

Approach	EB			WB			NB			SB		
HCM Control Delay, s	2.9			0.4			29.1			21.6		
HCM LOS							D			C		

Minor Lane/Major Mvmt	NBLn1	EBL	EBT	EBR	WBL	WBT	WBR	SBLn1
Capacity (veh/h)	220	1235	-	-	1279	-	-	478
HCM Lane V/C Ratio	0.327	0.121	-	-	0.013	-	-	0.556
HCM Control Delay (s)	29.1	8.3	-	-	7.9	-	-	21.6
HCM Lane LOS	D	A	-	-	A	-	-	C
HCM 95th %tile Q(veh)	1.4	0.4	-	-	0	-	-	3.3

Intersection												
Int Delay, s/veh	43.3											
Movement	EBL	EBT	EBR	WBL	WBT	WBR	NBL	NBT	NBR	SBL	SBT	SBR
Lane Configurations	↔	↔		↔	↔			↔			↔	↔
Traffic Vol, veh/h	274	268	12	4	287	69	10	1	3	62	1	258
Future Vol, veh/h	274	268	12	4	287	69	10	1	3	62	1	258
Conflicting Peds, #/hr	0	0	0	0	0	0	0	0	0	0	0	0
Sign Control	Free	Free	Free	Free	Free	Free	Stop	Stop	Stop	Stop	Stop	Stop
RT Channelized	-	-	None	-	-	None	-	-	None	-	-	None
Storage Length	65	-	-	90	-	-	-	-	-	-	-	-
Veh in Median Storage, #	-	0	-	-	0	-	-	0	-	-	0	-
Grade, %	-	0	-	-	0	-	-	0	-	-	0	-
Peak Hour Factor	93	89	60	50	81	62	62	25	38	85	25	90
Heavy Vehicles, %	2	2	2	2	2	2	2	2	2	2	2	2
Mvmt Flow	295	301	20	8	354	111	16	4	8	73	4	287

Major/Minor	Major1			Major2			Minor1			Minor2		
Conflicting Flow All	465	0	0	321	0	0	1472	1382	311	1333	1337	410
Stage 1	-	-	-	-	-	-	901	901	-	426	426	-
Stage 2	-	-	-	-	-	-	571	481	-	907	911	-
Critical Hdwy	4.12	-	-	4.12	-	-	7.12	6.52	6.22	7.12	6.52	6.22
Critical Hdwy Stg 1	-	-	-	-	-	-	6.12	5.52	-	6.12	5.52	-
Critical Hdwy Stg 2	-	-	-	-	-	-	6.12	5.52	-	6.12	5.52	-
Follow-up Hdwy	2.218	-	-	2.218	-	-	3.518	4.018	3.318	3.518	4.018	3.318
Pot Cap-1 Maneuver	1096	-	-	1239	-	-	105	144	729	131	153	642
Stage 1	-	-	-	-	-	-	333	357	-	606	586	-
Stage 2	-	-	-	-	-	-	506	554	-	330	353	-
Platoon blocked, %	-	-	-	-	-	-	-	-	-	-	-	-
Mov Cap-1 Maneuver	1096	-	-	1239	-	-	45	105	729	99	111	642
Mov Cap-2 Maneuver	-	-	-	-	-	-	45	105	-	99	111	-
Stage 1	-	-	-	-	-	-	243	261	-	443	582	-
Stage 2	-	-	-	-	-	-	276	551	-	235	258	-

Approach	EB		WB		NB		SB	
HCM Control Delay, s	4.5		0.1		89.1		161.9	
HCM LOS					F		F	

Minor Lane/Major Mvmt	NBLn1	EBL	EBT	EBR	WBL	WBT	WBR	SBLn1
Capacity (veh/h)	69	1096	-	-	1239	-	-	298
HCM Lane V/C Ratio	0.406	0.269	-	-	0.006	-	-	1.22
HCM Control Delay (s)	89.1	9.5	-	-	7.9	-	-	161.9
HCM Lane LOS	F	A	-	-	A	-	-	F
HCM 95th %tile Q(veh)	1.6	1.1	-	-	0	-	-	16.5

Intersection	
Intersection Delay, s/veh	8.6
Intersection LOS	A

Movement	EBL	EBT	EBR	WBL	WBT	WBR	NBL	NBT	NBR	SBL	SBT	SBR
Lane Configurations	↶	↷		↶	↷			↕		↶	↷	
Traffic Vol, veh/h	18	93	37	9	102	7	9	1	2	2	1	16
Future Vol, veh/h	18	93	37	9	102	7	9	1	2	2	1	16
Peak Hour Factor	0.64	0.86	0.46	0.45	0.94	0.44	0.56	0.25	0.50	0.25	0.25	0.50
Heavy Vehicles, %	2	2	2	2	2	2	2	2	2	2	2	2
Mvmt Flow	28	108	80	20	109	16	16	4	4	8	4	32
Number of Lanes	1	1	0	1	1	0	0	1	0	1	1	0

Approach	EB	WB	NB	SB
Opposing Approach	WB	EB	SB	NB
Opposing Lanes	2	2	2	1
Conflicting Approach Left	SB	NB	EB	WB
Conflicting Lanes Left	2	1	2	2
Conflicting Approach Right	NB	SB	WB	EB
Conflicting Lanes Right	1	2	2	2
HCM Control Delay	8.7	8.5	8.7	7.9
HCM LOS	A	A	A	A

Lane	NBLn1	EBLn1	EBLn2	WBLn1	WBLn2	SBLn1	SBLn2
Vol Left, %	75%	100%	0%	100%	0%	100%	0%
Vol Thru, %	8%	0%	72%	0%	94%	0%	6%
Vol Right, %	17%	0%	28%	0%	6%	0%	94%
Sign Control	Stop	Stop	Stop	Stop	Stop	Stop	Stop
Traffic Vol by Lane	12	18	130	9	109	2	17
LT Vol	9	18	0	9	0	2	0
Through Vol	1	0	93	0	102	0	1
RT Vol	2	0	37	0	7	0	16
Lane Flow Rate	24	28	189	20	124	8	36
Geometry Grp	6	7	7	7	7	7	7
Degree of Util (X)	0.037	0.042	0.243	0.03	0.167	0.013	0.048
Departure Headway (Hd)	5.494	5.332	4.631	5.386	4.839	5.919	4.754
Convergence, Y/N	Yes	Yes	Yes	Yes	Yes	Yes	Yes
Cap	653	674	779	667	744	606	754
Service Time	3.518	3.045	2.344	3.101	2.554	3.641	2.476
HCM Lane V/C Ratio	0.037	0.042	0.243	0.03	0.167	0.013	0.048
HCM Control Delay	8.7	8.3	8.8	8.3	8.5	8.7	7.7
HCM Lane LOS	A	A	A	A	A	A	A
HCM 95th-tile Q	0.1	0.1	1	0.1	0.6	0	0.2

Intersection	
Intersection Delay, s/veh	12.2
Intersection LOS	B

Movement	EBL	EBT	EBR	WBL	WBT	WBR	NBL	NBT	NBR	SBL	SBT	SBR
Lane Configurations	↶	↷		↶	↷			↷		↶	↷	
Traffic Vol, veh/h	74	235	24	10	231	45	31	3	11	30	0	92
Future Vol, veh/h	74	235	24	10	231	45	31	3	11	30	0	92
Peak Hour Factor	0.93	0.95	0.67	0.62	0.89	0.86	0.86	0.25	0.46	0.68	0.92	0.74
Heavy Vehicles, %	2	2	2	2	2	2	2	2	2	2	2	2
Mvmt Flow	80	247	36	16	260	52	36	12	24	44	0	124
Number of Lanes	1	1	0	1	1	0	0	1	0	1	1	0

Approach	EB	WB	NB	SB
Opposing Approach	WB	EB	SB	NB
Opposing Lanes	2	2	2	1
Conflicting Approach Left	SB	NB	EB	WB
Conflicting Lanes Left	2	1	2	2
Conflicting Approach Right	NB	SB	WB	EB
Conflicting Lanes Right	1	2	2	2
HCM Control Delay	12.2	13.5	10.8	10.1
HCM LOS	B	B	B	B

Lane	NBLn1	EBLn1	EBLn2	WBLn1	WBLn2	SBLn1	SBLn2
Vol Left, %	69%	100%	0%	100%	0%	100%	0%
Vol Thru, %	7%	0%	91%	0%	84%	0%	0%
Vol Right, %	24%	0%	9%	0%	16%	0%	100%
Sign Control	Stop	Stop	Stop	Stop	Stop	Stop	Stop
Traffic Vol by Lane	45	74	259	10	276	30	92
LT Vol	31	74	0	10	0	30	0
Through Vol	3	0	235	0	231	0	0
RT Vol	11	0	24	0	45	0	92
Lane Flow Rate	72	80	283	16	312	44	124
Geometry Grp	6	7	7	7	7	7	7
Degree of Util (X)	0.134	0.137	0.444	0.028	0.489	0.086	0.2
Departure Headway (Hd)	6.702	6.213	5.642	6.266	5.645	7.016	5.799
Convergence, Y/N	Yes	Yes	Yes	Yes	Yes	Yes	Yes
Cap	534	578	640	572	639	510	618
Service Time	4.752	3.946	3.375	4	3.378	4.76	3.542
HCM Lane V/C Ratio	0.135	0.138	0.442	0.028	0.488	0.086	0.201
HCM Control Delay	10.8	9.9	12.8	9.2	13.7	10.4	10
HCM Lane LOS	B	A	B	A	B	B	A
HCM 95th-tile Q	0.5	0.5	2.3	0.1	2.7	0.3	0.7

Intersection	
Intersection Delay, s/veh	16.8
Intersection LOS	C

Movement	EBL	EBT	EBR	WBL	WBT	WBR	NBL	NBT	NBR	SBL	SBT	SBR
Lane Configurations	↶	↷		↶	↷			↕		↶	↷	
Traffic Vol, veh/h	167	268	12	4	287	50	10	1	3	44	1	155
Future Vol, veh/h	167	268	12	4	287	50	10	1	3	44	1	155
Peak Hour Factor	0.93	0.89	0.60	0.50	0.81	0.62	0.62	0.25	0.38	0.85	0.25	0.90
Heavy Vehicles, %	2	2	2	2	2	2	2	2	2	2	2	2
Mvmt Flow	180	301	20	8	354	81	16	4	8	52	4	172
Number of Lanes	1	1	0	1	1	0	0	1	0	1	1	0

Approach	EB	WB	NB	SB
Opposing Approach	WB	EB	SB	NB
Opposing Lanes	2	2	2	1
Conflicting Approach Left	SB	NB	EB	WB
Conflicting Lanes Left	2	1	2	2
Conflicting Approach Right	NB	SB	WB	EB
Conflicting Lanes Right	1	2	2	2
HCM Control Delay	14.3	22.6	11.2	11.7
HCM LOS	B	C	B	B

Lane	NBLn1	EBLn1	EBLn2	WBLn1	WBLn2	SBLn1	SBLn2
Vol Left, %	71%	100%	0%	100%	0%	100%	0%
Vol Thru, %	7%	0%	96%	0%	85%	0%	1%
Vol Right, %	21%	0%	4%	0%	15%	0%	99%
Sign Control	Stop	Stop	Stop	Stop	Stop	Stop	Stop
Traffic Vol by Lane	14	167	280	4	337	44	156
LT Vol	10	167	0	4	0	44	0
Through Vol	1	0	268	0	287	0	1
RT Vol	3	0	12	0	50	0	155
Lane Flow Rate	28	180	321	8	435	52	176
Geometry Grp	6	7	7	7	7	7	7
Degree of Util (X)	0.059	0.324	0.531	0.015	0.722	0.108	0.31
Departure Headway (Hd)	7.61	6.493	5.955	6.586	5.973	7.543	6.324
Convergence, Y/N	Yes	Yes	Yes	Yes	Yes	Yes	Yes
Cap	468	553	604	542	605	474	566
Service Time	5.706	4.246	3.708	4.339	3.726	5.31	4.09
HCM Lane V/C Ratio	0.06	0.325	0.531	0.015	0.719	0.11	0.311
HCM Control Delay	11.2	12.4	15.3	9.4	22.8	11.2	11.9
HCM Lane LOS	B	B	C	A	C	B	B
HCM 95th-tile Q	0.2	1.4	3.1	0	6	0.4	1.3

Intersection	
Intersection Delay, s/veh	10.1
Intersection LOS	B

Movement	EBL	EBT	EBR	WBL	WBT	WBR	NBL	NBT	NBR	SBL	SBT	SBR
Lane Configurations	↶	↷		↶	↷			↕		↶	↷	
Traffic Vol, veh/h	96	93	37	9	102	21	9	1	2	15	1	92
Future Vol, veh/h	96	93	37	9	102	21	9	1	2	15	1	92
Peak Hour Factor	0.64	0.86	0.46	0.45	0.94	0.44	0.56	0.25	0.50	0.25	0.25	0.50
Heavy Vehicles, %	2	2	2	2	2	2	2	2	2	2	2	2
Mvmt Flow	150	108	80	20	109	48	16	4	4	60	4	184
Number of Lanes	1	1	0	1	1	0	0	1	0	1	1	0

Approach	EB	WB	NB	SB
Opposing Approach	WB	EB	SB	NB
Opposing Lanes	2	2	2	1
Conflicting Approach Left	SB	NB	EB	WB
Conflicting Lanes Left	2	1	2	2
Conflicting Approach Right	NB	SB	WB	EB
Conflicting Lanes Right	1	2	2	2
HCM Control Delay	10.3	10	9.6	9.8
HCM LOS	B	A	A	A

Lane	NBLn1	EBLn1	EBLn2	WBLn1	WBLn2	SBLn1	SBLn2
Vol Left, %	75%	100%	0%	100%	0%	100%	0%
Vol Thru, %	8%	0%	72%	0%	83%	0%	1%
Vol Right, %	17%	0%	28%	0%	17%	0%	99%
Sign Control	Stop	Stop	Stop	Stop	Stop	Stop	Stop
Traffic Vol by Lane	12	96	130	9	123	15	93
LT Vol	9	96	0	9	0	15	0
Through Vol	1	0	93	0	102	0	1
RT Vol	2	0	37	0	21	0	92
Lane Flow Rate	24	150	189	20	156	60	188
Geometry Grp	6	7	7	7	7	7	7
Degree of Util (X)	0.042	0.248	0.274	0.034	0.239	0.106	0.269
Departure Headway (Hd)	6.338	5.945	5.24	6.138	5.512	6.352	5.15
Convergence, Y/N	Yes	Yes	Yes	Yes	Yes	Yes	Yes
Cap	568	599	679	578	644	560	690
Service Time	4.338	3.732	3.027	3.937	3.311	4.135	2.932
HCM Lane V/C Ratio	0.042	0.25	0.278	0.035	0.242	0.107	0.272
HCM Control Delay	9.6	10.7	10	9.2	10.1	9.9	9.8
HCM Lane LOS	A	B	A	A	B	A	A
HCM 95th-tile Q	0.1	1	1.1	0.1	0.9	0.4	1.1

Intersection	
Intersection Delay, s/veh	13.7
Intersection LOS	B

Movement	EBL	EBT	EBR	WBL	WBT	WBR	NBL	NBT	NBR	SBL	SBT	SBR
Lane Configurations	↶	↷		↶	↷			↷		↶	↷	
Traffic Vol, veh/h	139	235	24	10	231	56	31	3	11	41	0	152
Future Vol, veh/h	139	235	24	10	231	56	31	3	11	41	0	152
Peak Hour Factor	0.93	0.95	0.67	0.62	0.89	0.86	0.86	0.25	0.46	0.68	0.92	0.74
Heavy Vehicles, %	2	2	2	2	2	2	2	2	2	2	2	2
Mvmt Flow	149	247	36	16	260	65	36	12	24	60	0	205
Number of Lanes	1	1	0	1	1	0	0	1	0	1	1	0

Approach	EB	WB	NB	SB
Opposing Approach	WB	EB	SB	NB
Opposing Lanes	2	2	2	1
Conflicting Approach Left	SB	NB	EB	WB
Conflicting Lanes Left	2	1	2	2
Conflicting Approach Right	NB	SB	WB	EB
Conflicting Lanes Right	1	2	2	2
HCM Control Delay	13.5	15.9	11.6	11.9
HCM LOS	B	C	B	B

Lane	NBLn1	EBLn1	EBLn2	WBLn1	WBLn2	SBLn1	SBLn2
Vol Left, %	69%	100%	0%	100%	0%	100%	0%
Vol Thru, %	7%	0%	91%	0%	80%	0%	0%
Vol Right, %	24%	0%	9%	0%	20%	0%	100%
Sign Control	Stop	Stop	Stop	Stop	Stop	Stop	Stop
Traffic Vol by Lane	45	139	259	10	287	41	152
LT Vol	31	139	0	10	0	41	0
Through Vol	3	0	235	0	231	0	0
RT Vol	11	0	24	0	56	0	152
Lane Flow Rate	72	149	283	16	325	60	205
Geometry Grp	6	7	7	7	7	7	7
Degree of Util (X)	0.145	0.276	0.477	0.03	0.552	0.122	0.348
Departure Headway (Hd)	7.233	6.639	6.065	6.772	6.125	7.312	6.092
Convergence, Y/N	Yes	Yes	Yes	Yes	Yes	Yes	Yes
Cap	492	540	592	527	588	488	587
Service Time	5.326	4.402	3.828	4.538	3.89	5.084	3.862
HCM Lane V/C Ratio	0.146	0.276	0.478	0.03	0.553	0.123	0.349
HCM Control Delay	11.6	11.9	14.3	9.7	16.2	11.1	12.1
HCM Lane LOS	B	B	B	A	C	B	B
HCM 95th-tile Q	0.5	1.1	2.6	0.1	3.4	0.4	1.6

Intersection	
Intersection Delay, s/veh	25.9
Intersection LOS	D

Movement	EBL	EBT	EBR	WBL	WBT	WBR	NBL	NBT	NBR	SBL	SBT	SBR
Lane Configurations	↶	↷		↶	↷			↷		↶	↷	
Traffic Vol, veh/h	274	268	12	4	287	69	10	1	3	62	1	258
Future Vol, veh/h	274	268	12	4	287	69	10	1	3	62	1	258
Peak Hour Factor	0.93	0.89	0.60	0.50	0.81	0.62	0.62	0.25	0.38	0.85	0.25	0.90
Heavy Vehicles, %	2	2	2	2	2	2	2	2	2	2	2	2
Mvmt Flow	295	301	20	8	354	111	16	4	8	73	4	287
Number of Lanes	1	1	0	1	1	0	0	1	0	1	1	0

Approach	EB	WB	NB	SB
Opposing Approach	WB	EB	SB	NB
Opposing Lanes	2	2	2	1
Conflicting Approach Left	SB	NB	EB	WB
Conflicting Lanes Left	2	1	2	2
Conflicting Approach Right	NB	SB	WB	EB
Conflicting Lanes Right	1	2	2	2
HCM Control Delay	19.9	41.6	12.5	16.8
HCM LOS	C	E	B	C

Lane	NBLn1	EBLn1	EBLn2	WBLn1	WBLn2	SBLn1	SBLn2
Vol Left, %	71%	100%	0%	100%	0%	100%	0%
Vol Thru, %	7%	0%	96%	0%	81%	0%	0%
Vol Right, %	21%	0%	4%	0%	19%	0%	100%
Sign Control	Stop	Stop	Stop	Stop	Stop	Stop	Stop
Traffic Vol by Lane	14	274	280	4	356	62	259
LT Vol	10	274	0	4	0	62	0
Through Vol	1	0	268	0	287	0	1
RT Vol	3	0	12	0	69	0	258
Lane Flow Rate	28	295	321	8	466	73	291
Geometry Grp	6	7	7	7	7	7	7
Degree of Util (X)	0.069	0.599	0.605	0.017	0.885	0.164	0.555
Departure Headway (Hd)	8.816	7.32	6.778	7.493	6.843	8.108	6.879
Convergence, Y/N	Yes	Yes	Yes	Yes	Yes	Yes	Yes
Cap	406	492	533	478	531	443	526
Service Time	6.884	5.061	4.518	5.232	4.581	5.846	4.617
HCM Lane V/C Ratio	0.069	0.6	0.602	0.017	0.878	0.165	0.553
HCM Control Delay	12.5	20.5	19.4	10.4	42.1	12.4	17.9
HCM Lane LOS	B	C	C	B	E	B	C
HCM 95th-tile Q	0.2	3.9	4	0.1	9.9	0.6	3.4

HCM 6th Signalized Intersection Summary
2: Dillon Ridge Road & US-6

2018 Existing AM.syn
07/30/2018

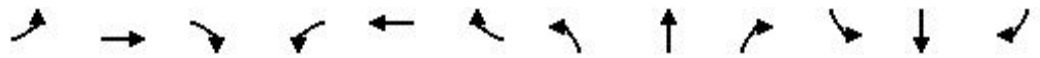

Movement	EBL	EBT	EBR	WBL	WBT	WBR	NBL	NBT	NBR	SBL	SBT	SBR
Lane Configurations												
Traffic Volume (veh/h)	129	540	23	14	518	29	20	5	10	15	0	125
Future Volume (veh/h)	129	540	23	14	518	29	20	5	10	15	0	125
Initial Q (Qb), veh	0	0	0	0	0	0	0	0	0	0	0	0
Ped-Bike Adj(A_pbT)	1.00		1.00	1.00		1.00	1.00		1.00	1.00		1.00
Parking Bus, Adj	1.00	1.00	1.00	1.00	1.00	1.00	1.00	1.00	1.00	1.00	1.00	1.00
Work Zone On Approach		No			No			No			No	
Adj Sat Flow, veh/h/ln	1870	1870	1870	1870	1870	1870	1870	1870	1870	1870	1870	1870
Adj Flow Rate, veh/h	193	593	44	20	551	44	22	26	12	24	0	78
Peak Hour Factor	0.67	0.91	0.52	0.70	0.94	0.66	0.62	0.42	0.83	0.62	0.92	0.84
Percent Heavy Veh, %	2	2	2	2	2	2	2	2	2	2	2	2
Cap, veh/h	643	2513	1121	601	2437	1087	139	145	123	111	0	99
Arrive On Green	0.04	0.71	0.71	0.02	0.69	0.69	0.08	0.08	0.08	0.06	0.00	0.06
Sat Flow, veh/h	1781	3554	1585	1781	3554	1585	1781	1870	1585	1781	0	1585
Grp Volume(v), veh/h	193	593	44	20	551	44	22	26	12	24	0	78
Grp Sat Flow(s),veh/h/ln	1781	1777	1585	1781	1777	1585	1781	1870	1585	1781	0	1585
Q Serve(g_s), s	4.4	7.9	1.1	0.5	7.8	1.2	1.6	1.8	0.9	1.7	0.0	6.6
Cycle Q Clear(g_c), s	4.4	7.9	1.1	0.5	7.8	1.2	1.6	1.8	0.9	1.7	0.0	6.6
Prop In Lane	1.00		1.00	1.00		1.00	1.00		1.00	1.00		1.00
Lane Grp Cap(c), veh/h	643	2513	1121	601	2437	1087	139	145	123	111	0	99
V/C Ratio(X)	0.30	0.24	0.04	0.03	0.23	0.04	0.16	0.18	0.10	0.22	0.00	0.79
Avail Cap(c_a), veh/h	643	2513	1121	639	2437	1087	139	145	123	139	0	123
HCM Platoon Ratio	1.00	1.00	1.00	1.00	1.00	1.00	1.00	1.00	1.00	1.00	1.00	1.00
Upstream Filter(I)	1.00	1.00	1.00	1.00	1.00	1.00	1.00	1.00	1.00	1.00	0.00	1.00
Uniform Delay (d), s/veh	5.9	7.0	6.0	6.0	7.9	6.9	58.1	58.2	57.8	60.2	0.0	62.4
Incr Delay (d2), s/veh	0.3	0.2	0.1	0.0	0.2	0.1	2.4	2.7	1.6	1.0	0.0	23.3
Initial Q Delay(d3),s/veh	0.0	0.0	0.0	0.0	0.0	0.0	0.0	0.0	0.0	0.0	0.0	0.0
%ile BackOfQ(50%),veh/ln	1.6	3.0	0.4	0.2	3.0	0.4	0.8	0.9	0.4	0.8	0.0	3.3
Unsig. Movement Delay, s/veh												
LnGrp Delay(d),s/veh	6.1	7.2	6.0	6.0	8.1	6.9	60.6	60.9	59.4	61.1	0.0	85.7
LnGrp LOS	A	A	A	A	A	A	E	E	E	E	A	F
Approach Vol, veh/h		830			615			60			102	
Approach Delay, s/veh		6.9			7.9			60.5			79.9	
Approach LOS		A			A			E			E	
Timer - Assigned Phs		2	3	4		6	7	8				
Phs Duration (G+Y+Rc), s		15.0	7.1	99.9		12.9	10.0	97.1				
Change Period (Y+Rc), s		4.5	4.5	4.5		4.5	4.5	4.5				
Max Green Setting (Gmax), s		10.5	5.5	90.5		10.5	5.5	90.5				
Max Q Clear Time (g_c+I1), s		3.8	2.5	9.9		8.6	6.4	9.8				
Green Ext Time (p_c), s		0.1	0.0	4.9		0.0	0.0	4.5				

Intersection Summary

HCM 6th Ctrl Delay	13.9
HCM 6th LOS	B

Notes

- User approved pedestrian interval to be less than phase max green.
- User approved volume balancing among the lanes for turning movement.

HCM 6th Signalized Intersection Summary
 2: Dillon Ridge Road & US-6

2018 Existing PM.syn
 07/30/2018

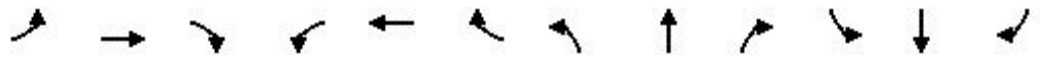

Movement	EBL	EBT	EBR	WBL	WBT	WBR	NBL	NBT	NBR	SBL	SBT	SBR
Lane Configurations												
Traffic Volume (veh/h)	272	674	49	48	692	29	57	31	49	28	9	313
Future Volume (veh/h)	272	674	49	48	692	29	57	31	49	28	9	313
Initial Q (Qb), veh	0	0	0	0	0	0	0	0	0	0	0	0
Ped-Bike Adj(A_pbT)	1.00		1.00	1.00		1.00	1.00		1.00	1.00		1.00
Parking Bus, Adj	1.00	1.00	1.00	1.00	1.00	1.00	1.00	1.00	1.00	1.00	1.00	1.00
Work Zone On Approach		No			No			No			No	
Adj Sat Flow, veh/h/ln	1870	1870	1870	1870	1870	1870	1870	1870	1870	1870	1870	1870
Adj Flow Rate, veh/h	292	717	64	68	721	40	50	56	68	56	12	108
Peak Hour Factor	0.93	0.94	0.77	0.71	0.96	0.72	0.89	0.86	0.72	0.50	0.75	0.95
Percent Heavy Veh, %	2	2	2	2	2	2	2	2	2	2	2	2
Cap, veh/h	554	2270	1012	505	2103	938	156	164	139	128	27	137
Arrive On Green	0.08	0.64	0.64	0.04	0.59	0.59	0.09	0.09	0.09	0.09	0.09	0.09
Sat Flow, veh/h	1781	3554	1585	1781	3554	1585	1781	1870	1585	1479	317	1585
Grp Volume(v), veh/h	292	717	64	68	721	40	50	56	68	68	0	108
Grp Sat Flow(s),veh/h/ln	1781	1777	1585	1781	1777	1585	1781	1870	1585	1796	0	1585
Q Serve(g_s), s	7.2	11.0	1.8	1.8	12.5	1.3	3.2	3.4	4.9	4.3	0.0	8.0
Cycle Q Clear(g_c), s	7.2	11.0	1.8	1.8	12.5	1.3	3.2	3.4	4.9	4.3	0.0	8.0
Prop In Lane	1.00		1.00	1.00		1.00	1.00		1.00	0.82		1.00
Lane Grp Cap(c), veh/h	554	2270	1012	505	2103	938	156	164	139	155	0	137
V/C Ratio(X)	0.53	0.32	0.06	0.13	0.34	0.04	0.32	0.34	0.49	0.44	0.00	0.79
Avail Cap(c_a), veh/h	952	2270	1012	716	2103	938	156	164	139	271	0	239
HCM Platoon Ratio	1.00	1.00	1.00	1.00	1.00	1.00	1.00	1.00	1.00	1.00	1.00	1.00
Upstream Filter(I)	1.00	1.00	1.00	1.00	1.00	1.00	1.00	1.00	1.00	1.00	0.00	1.00
Uniform Delay (d), s/veh	8.3	9.8	8.2	8.7	12.5	10.3	51.4	51.5	52.2	52.0	0.0	53.7
Incr Delay (d2), s/veh	0.8	0.4	0.1	0.1	0.4	0.1	5.4	5.6	11.9	1.9	0.0	9.6
Initial Q Delay(d3),s/veh	0.0	0.0	0.0	0.0	0.0	0.0	0.0	0.0	0.0	0.0	0.0	0.0
%ile BackOfQ(50%),veh/ln	2.7	4.2	0.6	0.7	5.0	0.5	1.6	1.8	2.4	2.0	0.0	3.6
Unsig. Movement Delay, s/veh												
LnGrp Delay(d),s/veh	9.0	10.2	8.3	8.8	13.0	10.3	56.8	57.1	64.1	54.0	0.0	63.3
LnGrp LOS	A	B	A	A	B	B	E	E	E	D	A	E
Approach Vol, veh/h		1073			829			174				176
Approach Delay, s/veh		9.8			12.5			59.7				59.7
Approach LOS		A			B			E				E
Timer - Assigned Phs		2	3	4		6	7	8				
Phs Duration (G+Y+Rc), s		15.0	9.0	81.1		14.9	14.6	75.5				
Change Period (Y+Rc), s		4.5	4.5	4.5		4.5	4.5	4.5				
Max Green Setting (Gmax), s		10.5	18.7	54.7		18.1	36.9	36.5				
Max Q Clear Time (g_c+I1), s		6.9	3.8	13.0		10.0	9.2	14.5				
Green Ext Time (p_c), s		0.2	0.1	6.1		0.4	0.9	5.3				

Intersection Summary

HCM 6th Ctrl Delay	18.5
HCM 6th LOS	B

Notes

- User approved pedestrian interval to be less than phase max green.
- User approved volume balancing among the lanes for turning movement.

HCM 6th Signalized Intersection Summary
2: Dillon Ridge Road & US-6

2018 Existing Saturday.syn
09/06/2018

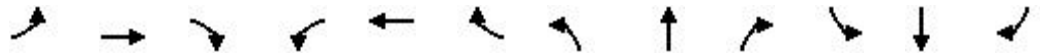

Movement	EBL	EBT	EBR	WBL	WBT	WBR	NBL	NBT	NBR	SBL	SBT	SBR
Lane Configurations	↖	↗	↘	↖	↗	↘	↖	↗	↘		↗	↘
Traffic Volume (veh/h)	402	912	77	42	750	42	87	14	60	45	20	413
Future Volume (veh/h)	402	912	77	42	750	42	87	14	60	45	20	413
Initial Q (Qb), veh	0	0	0	0	0	0	0	0	0	0	0	0
Ped-Bike Adj(A_pbT)	1.00		1.00	1.00		1.00	1.00		1.00	1.00		1.00
Parking Bus, Adj	1.00	1.00	1.00	1.00	1.00	1.00	1.00	1.00	1.00	1.00	1.00	1.00
Work Zone On Approach		No			No			No			No	
Adj Sat Flow, veh/h/ln	1870	1870	1870	1870	1870	1870	1870	1870	1870	1870	1870	1870
Adj Flow Rate, veh/h	442	1013	68	56	852	21	127	0	50	60	28	16
Peak Hour Factor	0.91	0.90	0.77	0.75	0.88	0.81	0.75	0.88	0.71	0.75	0.71	0.82
Percent Heavy Veh, %	2	2	2	2	2	2	2	2	2	2	2	2
Cap, veh/h	576	2560	1142	429	2324	1036	172	0	76	81	38	104
Arrive On Green	0.10	0.72	0.72	0.03	0.65	0.65	0.05	0.00	0.05	0.07	0.07	0.07
Sat Flow, veh/h	1781	3554	1585	1781	3554	1585	3563	0	1585	1233	575	1585
Grp Volume(v), veh/h	442	1013	68	56	852	21	127	0	50	88	0	16
Grp Sat Flow(s),veh/h/ln	1781	1777	1585	1781	1777	1585	1781	0	1585	1809	0	1585
Q Serve(g_s), s	10.3	15.0	1.7	1.4	14.7	0.6	4.8	0.0	4.2	6.5	0.0	1.3
Cycle Q Clear(g_c), s	10.3	15.0	1.7	1.4	14.7	0.6	4.8	0.0	4.2	6.5	0.0	1.3
Prop In Lane	1.00		1.00	1.00		1.00	1.00		1.00	0.68		1.00
Lane Grp Cap(c), veh/h	576	2560	1142	429	2324	1036	172	0	76	119	0	104
V/C Ratio(X)	0.77	0.40	0.06	0.13	0.37	0.02	0.74	0.00	0.66	0.74	0.00	0.15
Avail Cap(c_a), veh/h	683	2560	1142	655	2324	1036	172	0	76	931	0	816
HCM Platoon Ratio	1.00	1.00	1.00	1.00	1.00	1.00	1.00	1.00	1.00	1.00	1.00	1.00
Upstream Filter(I)	1.00	1.00	1.00	1.00	1.00	1.00	1.00	0.00	1.00	1.00	0.00	1.00
Uniform Delay (d), s/veh	8.3	7.4	5.5	7.0	10.6	8.2	63.4	0.0	63.1	61.9	0.0	59.5
Incr Delay (d2), s/veh	4.4	0.5	0.1	0.1	0.4	0.0	24.7	0.0	36.3	8.8	0.0	0.7
Initial Q Delay(d3),s/veh	0.0	0.0	0.0	0.0	0.0	0.0	0.0	0.0	0.0	0.0	0.0	0.0
%ile BackOfQ(50%),veh/ln	4.1	5.6	0.6	0.5	5.8	0.2	2.7	0.0	2.5	3.3	0.0	0.5
Unsig. Movement Delay, s/veh												
LnGrp Delay(d),s/veh	12.7	7.8	5.6	7.1	11.1	8.2	88.1	0.0	99.5	70.7	0.0	60.2
LnGrp LOS	B	A	A	A	B	A	F	A	F	E	A	E
Approach Vol, veh/h		1523			929			177				104
Approach Delay, s/veh		9.1			10.8			91.3				69.1
Approach LOS		A			B			F				E
Timer - Assigned Phs		2	3	4		6	7	8				
Phs Duration (G+Y+Rc), s		11.0	8.9	101.8		13.4	17.9	92.8				
Change Period (Y+Rc), s		4.5	4.5	4.5		4.5	4.5	4.5				
Max Green Setting (Gmax), s		6.5	21.5	19.5		69.5	21.5	19.5				
Max Q Clear Time (g_c+I1), s		6.8	3.4	17.0		8.5	12.3	16.7				
Green Ext Time (p_c), s		0.0	0.1	1.6		0.6	1.0	1.5				

Intersection Summary

HCM 6th Ctrl Delay	17.3
HCM 6th LOS	B

Notes

- User approved pedestrian interval to be less than phase max green.
- User approved volume balancing among the lanes for turning movement.

HCM 6th Signalized Intersection Summary
2: Dillon Ridge Road & US-6

2020 BG AM.syn
08/29/2018



Movement	EBL	EBT	EBR	WBL	WBT	WBR	NBL	NBT	NBR	SBL	SBT	SBR
Lane Configurations	↘	↑↑	↗	↘	↑↑	↗	↘	↗	↗		↗	↗
Traffic Volume (veh/h)	129	556	23	14	534	29	20	5	10	15	0	125
Future Volume (veh/h)	129	556	23	14	534	29	20	5	10	15	0	125
Initial Q (Qb), veh	0	0	0	0	0	0	0	0	0	0	0	0
Ped-Bike Adj(A_pbT)	1.00		1.00	1.00		1.00	1.00		1.00	1.00		1.00
Parking Bus, Adj	1.00	1.00	1.00	1.00	1.00	1.00	1.00	1.00	1.00	1.00	1.00	1.00
Work Zone On Approach		No			No			No			No	
Adj Sat Flow, veh/h/ln	1870	1870	1870	1870	1870	1870	1870	1870	1870	1870	1870	1870
Adj Flow Rate, veh/h	193	611	44	20	568	44	22	26	12	24	0	78
Peak Hour Factor	0.67	0.91	0.52	0.70	0.94	0.66	0.62	0.42	0.83	0.62	0.92	0.84
Percent Heavy Veh, %	2	2	2	2	2	2	2	2	2	2	2	2
Cap, veh/h	633	2513	1121	591	2437	1087	139	145	123	111	0	99
Arrive On Green	0.04	0.71	0.71	0.02	0.69	0.69	0.08	0.08	0.08	0.06	0.00	0.06
Sat Flow, veh/h	1781	3554	1585	1781	3554	1585	1781	1870	1585	1781	0	1585
Grp Volume(v), veh/h	193	611	44	20	568	44	22	26	12	24	0	78
Grp Sat Flow(s),veh/h/ln	1781	1777	1585	1781	1777	1585	1781	1870	1585	1781	0	1585
Q Serve(g_s), s	4.4	8.2	1.1	0.5	8.1	1.2	1.6	1.8	0.9	1.7	0.0	6.6
Cycle Q Clear(g_c), s	4.4	8.2	1.1	0.5	8.1	1.2	1.6	1.8	0.9	1.7	0.0	6.6
Prop In Lane	1.00		1.00	1.00		1.00	1.00		1.00	1.00		1.00
Lane Grp Cap(c), veh/h	633	2513	1121	591	2437	1087	139	145	123	111	0	99
V/C Ratio(X)	0.30	0.24	0.04	0.03	0.23	0.04	0.16	0.18	0.10	0.22	0.00	0.79
Avail Cap(c_a), veh/h	633	2513	1121	629	2437	1087	139	145	123	139	0	123
HCM Platoon Ratio	1.00	1.00	1.00	1.00	1.00	1.00	1.00	1.00	1.00	1.00	1.00	1.00
Upstream Filter(I)	1.00	1.00	1.00	1.00	1.00	1.00	1.00	1.00	1.00	1.00	0.00	1.00
Uniform Delay (d), s/veh	5.9	7.0	6.0	6.0	7.9	6.9	58.1	58.2	57.8	60.2	0.0	62.4
Incr Delay (d2), s/veh	0.3	0.2	0.1	0.0	0.2	0.1	2.4	2.7	1.6	1.0	0.0	23.3
Initial Q Delay(d3),s/veh	0.0	0.0	0.0	0.0	0.0	0.0	0.0	0.0	0.0	0.0	0.0	0.0
%ile BackOfQ(50%),veh/ln	1.6	3.1	0.4	0.2	3.1	0.4	0.8	0.9	0.4	0.8	0.0	3.3
Unsig. Movement Delay, s/veh												
LnGrp Delay(d),s/veh	6.2	7.2	6.0	6.1	8.2	6.9	60.6	60.9	59.4	61.1	0.0	85.7
LnGrp LOS	A	A	A	A	A	A	E	E	E	E	A	F
Approach Vol, veh/h		848			632			60			102	
Approach Delay, s/veh		6.9			8.0			60.5			79.9	
Approach LOS		A			A			E			E	
Timer - Assigned Phs		2	3	4		6	7	8				
Phs Duration (G+Y+Rc), s		15.0	7.1	99.9		12.9	10.0	97.1				
Change Period (Y+Rc), s		4.5	4.5	4.5		4.5	4.5	4.5				
Max Green Setting (Gmax), s		10.5	5.5	90.5		10.5	5.5	90.5				
Max Q Clear Time (g_c+I1), s		3.8	2.5	10.2		8.6	6.4	10.1				
Green Ext Time (p_c), s		0.1	0.0	5.1		0.0	0.0	4.7				

Intersection Summary

HCM 6th Ctrl Delay	13.8
HCM 6th LOS	B

Notes

- User approved pedestrian interval to be less than phase max green.
- User approved volume balancing among the lanes for turning movement.

HCM 6th Signalized Intersection Summary
2: Dillon Ridge Road & US-6

2020 BG PM.syn
09/05/2018



Movement	EBL	EBT	EBR	WBL	WBT	WBR	NBL	NBT	NBR	SBL	SBT	SBR
Lane Configurations	↖	↗	↘	↖	↗	↘	↖	↗	↘		↗	↘
Traffic Volume (veh/h)	272	694	49	48	713	29	57	31	49	28	9	313
Future Volume (veh/h)	272	694	49	48	713	29	57	31	49	28	9	313
Initial Q (Qb), veh	0	0	0	0	0	0	0	0	0	0	0	0
Ped-Bike Adj(A_pbT)	1.00		1.00	1.00		1.00	1.00		1.00	1.00		1.00
Parking Bus, Adj	1.00	1.00	1.00	1.00	1.00	1.00	1.00	1.00	1.00	1.00	1.00	1.00
Work Zone On Approach		No			No			No			No	
Adj Sat Flow, veh/h/ln	1870	1870	1870	1870	1870	1870	1870	1870	1870	1870	1870	1870
Adj Flow Rate, veh/h	292	738	32	68	743	5	50	56	33	56	12	140
Peak Hour Factor	0.93	0.94	0.77	0.71	0.96	0.72	0.89	0.86	0.72	0.50	0.75	0.95
Percent Heavy Veh, %	2	2	2	2	2	2	2	2	2	2	2	2
Cap, veh/h	572	2351	1049	527	2200	981	82	86	73	156	33	167
Arrive On Green	0.08	0.66	0.66	0.04	0.62	0.62	0.05	0.05	0.05	0.11	0.11	0.11
Sat Flow, veh/h	1781	3554	1585	1781	3554	1585	1781	1870	1585	1479	317	1585
Grp Volume(v), veh/h	292	738	32	68	743	5	50	56	33	68	0	140
Grp Sat Flow(s),veh/h/ln	1781	1777	1585	1781	1777	1585	1781	1870	1585	1796	0	1585
Q Serve(g_s), s	6.7	10.6	0.8	1.6	12.1	0.1	3.3	3.5	2.4	4.2	0.0	10.4
Cycle Q Clear(g_c), s	6.7	10.6	0.8	1.6	12.1	0.1	3.3	3.5	2.4	4.2	0.0	10.4
Prop In Lane	1.00		1.00	1.00		1.00	1.00		1.00	0.82		1.00
Lane Grp Cap(c), veh/h	572	2351	1049	527	2200	981	82	86	73	189	0	167
V/C Ratio(X)	0.51	0.31	0.03	0.13	0.34	0.01	0.61	0.65	0.45	0.36	0.00	0.84
Avail Cap(c_a), veh/h	1091	2351	1049	1151	2200	981	82	86	73	232	0	205
HCM Platoon Ratio	1.00	1.00	1.00	1.00	1.00	1.00	1.00	1.00	1.00	1.00	1.00	1.00
Upstream Filter(I)	1.00	1.00	1.00	1.00	1.00	1.00	1.00	1.00	1.00	1.00	0.00	1.00
Uniform Delay (d), s/veh	7.2	8.7	7.0	7.5	11.0	8.7	56.2	56.3	55.8	49.9	0.0	52.7
Incr Delay (d2), s/veh	0.7	0.3	0.1	0.1	0.4	0.0	29.8	32.7	19.1	1.2	0.0	22.0
Initial Q Delay(d3),s/veh	0.0	0.0	0.0	0.0	0.0	0.0	0.0	0.0	0.0	0.0	0.0	0.0
%ile BackOfQ(50%),veh/ln	2.4	4.0	0.3	0.6	4.7	0.1	2.2	2.4	1.4	2.0	0.0	5.1
Unsig. Movement Delay, s/veh												
LnGrp Delay(d),s/veh	7.9	9.0	7.1	7.6	11.4	8.7	86.0	89.0	74.9	51.1	0.0	74.7
LnGrp LOS	A	A	A	A	B	A	F	F	E	D	A	E
Approach Vol, veh/h		1062			816			139			208	
Approach Delay, s/veh		8.7			11.1			84.6			67.0	
Approach LOS		A			B			F			E	
Timer - Assigned Phs		2	3	4		6	7	8				
Phs Duration (G+Y+Rc), s		10.0	9.0	83.9		17.1	14.1	78.8				
Change Period (Y+Rc), s		4.5	4.5	4.5		4.5	4.5	4.5				
Max Green Setting (Gmax), s		5.5	46.5	34.5		15.5	44.5	36.5				
Max Q Clear Time (g_c+I1), s		5.5	3.6	12.6		12.4	8.7	14.1				
Green Ext Time (p_c), s		0.0	0.2	5.4		0.2	0.9	5.4				

Intersection Summary

HCM 6th Ctrl Delay	19.7
HCM 6th LOS	B

Notes

- User approved pedestrian interval to be less than phase max green.
- User approved volume balancing among the lanes for turning movement.

HCM 6th Signalized Intersection Summary
 2: Dillon Ridge Road & US-6

2020 BG Saturday.syn
 09/06/2018

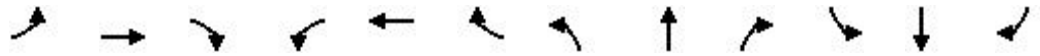

Movement	EBL	EBT	EBR	WBL	WBT	WBR	NBL	NBT	NBR	SBL	SBT	SBR
Lane Configurations												
Traffic Volume (veh/h)	402	940	77	42	773	42	87	14	60	45	20	413
Future Volume (veh/h)	402	940	77	42	773	42	87	14	60	45	20	413
Initial Q (Qb), veh	0	0	0	0	0	0	0	0	0	0	0	0
Ped-Bike Adj(A_pbT)	1.00		1.00	1.00		1.00	1.00		1.00	1.00		1.00
Parking Bus, Adj	1.00	1.00	1.00	1.00	1.00	1.00	1.00	1.00	1.00	1.00	1.00	1.00
Work Zone On Approach		No			No			No			No	
Adj Sat Flow, veh/h/ln	1870	1870	1870	1870	1870	1870	1870	1870	1870	1870	1870	1870
Adj Flow Rate, veh/h	442	1044	68	56	878	21	127	0	50	60	28	16
Peak Hour Factor	0.91	0.90	0.77	0.75	0.88	0.81	0.75	0.88	0.71	0.75	0.71	0.82
Percent Heavy Veh, %	2	2	2	2	2	2	2	2	2	2	2	2
Cap, veh/h	564	2560	1142	417	2324	1036	172	0	76	81	38	104
Arrive On Green	0.10	0.72	0.72	0.03	0.65	0.65	0.05	0.00	0.05	0.07	0.07	0.07
Sat Flow, veh/h	1781	3554	1585	1781	3554	1585	3563	0	1585	1233	575	1585
Grp Volume(v), veh/h	442	1044	68	56	878	21	127	0	50	88	0	16
Grp Sat Flow(s),veh/h/ln	1781	1777	1585	1781	1777	1585	1781	0	1585	1809	0	1585
Q Serve(g_s), s	10.3	15.7	1.7	1.4	15.3	0.6	4.8	0.0	4.2	6.5	0.0	1.3
Cycle Q Clear(g_c), s	10.3	15.7	1.7	1.4	15.3	0.6	4.8	0.0	4.2	6.5	0.0	1.3
Prop In Lane	1.00		1.00	1.00		1.00	1.00		1.00	0.68		1.00
Lane Grp Cap(c), veh/h	564	2560	1142	417	2324	1036	172	0	76	119	0	104
V/C Ratio(X)	0.78	0.41	0.06	0.13	0.38	0.02	0.74	0.00	0.66	0.74	0.00	0.15
Avail Cap(c_a), veh/h	672	2560	1142	643	2324	1036	172	0	76	931	0	816
HCM Platoon Ratio	1.00	1.00	1.00	1.00	1.00	1.00	1.00	1.00	1.00	1.00	1.00	1.00
Upstream Filter(I)	1.00	1.00	1.00	1.00	1.00	1.00	1.00	0.00	1.00	1.00	0.00	1.00
Uniform Delay (d), s/veh	8.7	7.5	5.5	7.0	10.7	8.2	63.4	0.0	63.1	61.9	0.0	59.5
Incr Delay (d2), s/veh	5.1	0.5	0.1	0.1	0.5	0.0	24.7	0.0	36.3	8.8	0.0	0.7
Initial Q Delay(d3),s/veh	0.0	0.0	0.0	0.0	0.0	0.0	0.0	0.0	0.0	0.0	0.0	0.0
%ile BackOfQ(50%),veh/ln	4.2	5.8	0.6	0.5	6.0	0.2	2.7	0.0	2.5	3.3	0.0	0.5
Unsig. Movement Delay, s/veh												
LnGrp Delay(d),s/veh	13.8	8.0	5.6	7.2	11.2	8.2	88.1	0.0	99.5	70.7	0.0	60.2
LnGrp LOS	B	A	A	A	B	A	F	A	F	E	A	E
Approach Vol, veh/h		1554			955			177				104
Approach Delay, s/veh		9.5			10.9			91.3				69.1
Approach LOS		A			B			F				E
Timer - Assigned Phs		2	3	4		6	7	8				
Phs Duration (G+Y+Rc), s		11.0	8.9	101.8		13.4	17.9	92.8				
Change Period (Y+Rc), s		4.5	4.5	4.5		4.5	4.5	4.5				
Max Green Setting (Gmax), s		6.5	21.5	19.5		69.5	21.5	19.5				
Max Q Clear Time (g_c+I1), s		6.8	3.4	17.7		8.5	12.3	17.3				
Green Ext Time (p_c), s		0.0	0.1	1.2		0.6	1.0	1.2				

Intersection Summary

HCM 6th Ctrl Delay	17.4
HCM 6th LOS	B

Notes

- User approved pedestrian interval to be less than phase max green.
- User approved volume balancing among the lanes for turning movement.

HCM 6th Signalized Intersection Summary
2: Dillon Ridge Road & US-6

2020 Total AM.syn
08/29/2018

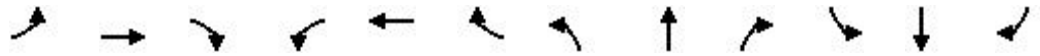

Movement	EBL	EBT	EBR	WBL	WBT	WBR	NBL	NBT	NBR	SBL	SBT	SBR
Lane Configurations	↖	↗	↘	↖	↗	↘	↖	↗	↘		↗	↘
Traffic Volume (veh/h)	175	556	23	14	534	57	20	10	10	42	4	170
Future Volume (veh/h)	175	556	23	14	534	57	20	10	10	42	4	170
Initial Q (Qb), veh	0	0	0	0	0	0	0	0	0	0	0	0
Ped-Bike Adj(A_pbT)	1.00		1.00	1.00		1.00	1.00		1.00	1.00		1.00
Parking Bus, Adj	1.00	1.00	1.00	1.00	1.00	1.00	1.00	1.00	1.00	1.00	1.00	1.00
Work Zone On Approach		No			No			No			No	
Adj Sat Flow, veh/h/ln	1870	1870	1870	1870	1870	1870	1870	1870	1870	1870	1870	1870
Adj Flow Rate, veh/h	261	611	44	20	568	86	28	30	12	68	4	131
Peak Hour Factor	0.67	0.91	0.52	0.70	0.94	0.66	0.62	0.42	0.83	0.62	0.92	0.84
Percent Heavy Veh, %	2	2	2	2	2	2	2	2	2	2	2	2
Cap, veh/h	599	2458	1096	576	2382	1063	139	145	123	131	8	123
Arrive On Green	0.04	0.69	0.69	0.02	0.67	0.67	0.08	0.08	0.08	0.08	0.08	0.08
Sat Flow, veh/h	1781	3554	1585	1781	3554	1585	1781	1870	1585	1687	99	1585
Grp Volume(v), veh/h	261	611	44	20	568	86	28	30	12	72	0	131
Grp Sat Flow(s),veh/h/ln	1781	1777	1585	1781	1777	1585	1781	1870	1585	1786	0	1585
Q Serve(g_s), s	5.5	8.6	1.2	0.5	8.5	2.6	2.0	2.0	0.9	5.2	0.0	10.5
Cycle Q Clear(g_c), s	5.5	8.6	1.2	0.5	8.5	2.6	2.0	2.0	0.9	5.2	0.0	10.5
Prop In Lane	1.00		1.00	1.00		1.00	1.00		1.00	0.94		1.00
Lane Grp Cap(c), veh/h	599	2458	1096	576	2382	1063	139	145	123	139	0	123
V/C Ratio(X)	0.44	0.25	0.04	0.03	0.24	0.08	0.20	0.21	0.10	0.52	0.00	1.06
Avail Cap(c_a), veh/h	599	2458	1096	614	2382	1063	139	145	123	139	0	123
HCM Platoon Ratio	1.00	1.00	1.00	1.00	1.00	1.00	1.00	1.00	1.00	1.00	1.00	1.00
Upstream Filter(I)	1.00	1.00	1.00	1.00	1.00	1.00	1.00	1.00	1.00	1.00	0.00	1.00
Uniform Delay (d), s/veh	7.6	7.8	6.6	6.7	8.7	7.8	58.3	58.3	57.8	59.8	0.0	62.3
Incr Delay (d2), s/veh	0.5	0.2	0.1	0.0	0.2	0.1	3.3	3.2	1.6	3.4	0.0	98.8
Initial Q Delay(d3),s/veh	0.0	0.0	0.0	0.0	0.0	0.0	0.0	0.0	0.0	0.0	0.0	0.0
%ile BackOfQ(50%),veh/ln	2.5	3.3	0.4	0.2	3.3	0.9	1.0	1.1	0.4	2.5	0.0	7.6
Unsig. Movement Delay, s/veh												
LnGrp Delay(d),s/veh	8.1	8.0	6.7	6.7	9.0	7.9	61.6	61.5	59.4	63.2	0.0	161.1
LnGrp LOS	A	A	A	A	A	A	E	E	E	E	A	F
Approach Vol, veh/h		916			674			70			203	
Approach Delay, s/veh		8.0			8.8			61.2			126.4	
Approach LOS		A			A			E			F	
Timer - Assigned Phs		2	3	4		6	7	8				
Phs Duration (G+Y+Rc), s		15.0	7.1	97.9		15.0	10.0	95.0				
Change Period (Y+Rc), s		4.5	4.5	4.5		4.5	4.5	4.5				
Max Green Setting (Gmax), s		10.5	5.5	90.5		10.5	5.5	90.5				
Max Q Clear Time (g_c+l1), s		4.0	2.5	10.6		12.5	7.5	10.5				
Green Ext Time (p_c), s		0.1	0.0	5.1		0.0	0.0	4.8				

Intersection Summary

HCM 6th Ctrl Delay	23.2
HCM 6th LOS	C

Notes

- User approved pedestrian interval to be less than phase max green.
- User approved volume balancing among the lanes for turning movement.

HCM 6th Signalized Intersection Summary
2: Dillon Ridge Road & US-6























2020 Total PM.syn
09/05/2018



Movement	EBL	EBT	EBR	WBL	WBT	WBR	NBL	NBT	NBR	SBL	SBT	SBR
Lane Configurations	↘	↑↑	↗	↘	↑↑	↗	↘	↗	↗		↗	↗
Traffic Volume (veh/h)	310	694	49	48	713	52	57	35	49	49	13	349
Future Volume (veh/h)	310	694	49	48	713	52	57	35	49	49	13	349
Initial Q (Qb), veh	0	0	0	0	0	0	0	0	0	0	0	0
Ped-Bike Adj(A_pbT)	1.00		1.00	1.00		1.00	1.00		1.00	1.00		1.00
Parking Bus, Adj	1.00	1.00	1.00	1.00	1.00	1.00	1.00	1.00	1.00	1.00	1.00	1.00
Work Zone On Approach		No			No			No			No	
Adj Sat Flow, veh/h/ln	1870	1870	1870	1870	1870	1870	1870	1870	1870	1870	1870	1870
Adj Flow Rate, veh/h	333	738	64	68	743	72	52	57	68	98	17	241
Peak Hour Factor	0.93	0.94	0.77	0.71	0.96	0.72	0.89	0.86	0.72	0.50	0.75	0.95
Percent Heavy Veh, %	2	2	2	2	2	2	2	2	2	2	2	2
Cap, veh/h	451	1751	781	371	1431	638	269	282	239	258	45	268
Arrive On Green	0.13	0.49	0.49	0.04	0.40	0.40	0.15	0.15	0.15	0.17	0.17	0.17
Sat Flow, veh/h	1781	3554	1585	1781	3554	1585	1781	1870	1585	1529	265	1585
Grp Volume(v), veh/h	333	738	64	68	743	72	52	57	68	115	0	241
Grp Sat Flow(s),veh/h/ln	1781	1777	1585	1781	1777	1585	1781	1870	1585	1794	0	1585
Q Serve(g_s), s	12.5	16.0	2.6	2.7	18.9	3.4	3.1	3.2	4.6	6.8	0.0	17.9
Cycle Q Clear(g_c), s	12.5	16.0	2.6	2.7	18.9	3.4	3.1	3.2	4.6	6.8	0.0	17.9
Prop In Lane	1.00		1.00	1.00		1.00	1.00		1.00	0.85		1.00
Lane Grp Cap(c), veh/h	451	1751	781	371	1431	638	269	282	239	303	0	268
V/C Ratio(X)	0.74	0.42	0.08	0.18	0.52	0.11	0.19	0.20	0.28	0.38	0.00	0.90
Avail Cap(c_a), veh/h	603	1751	781	387	1431	638	269	282	239	336	0	297
HCM Platoon Ratio	1.00	1.00	1.00	1.00	1.00	1.00	1.00	1.00	1.00	1.00	1.00	1.00
Upstream Filter(I)	1.00	1.00	1.00	1.00	1.00	1.00	1.00	1.00	1.00	1.00	0.00	1.00
Uniform Delay (d), s/veh	18.8	19.5	16.1	19.7	27.1	22.4	44.6	44.6	45.2	44.3	0.0	48.9
Incr Delay (d2), s/veh	3.3	0.7	0.2	0.2	1.3	0.4	1.6	1.6	3.0	0.8	0.0	26.7
Initial Q Delay(d3),s/veh	0.0	0.0	0.0	0.0	0.0	0.0	0.0	0.0	0.0	0.0	0.0	0.0
%ile BackOfQ(50%),veh/ln	5.4	6.7	1.0	1.1	8.3	1.3	1.5	1.6	2.0	3.1	0.0	9.0
Unsig. Movement Delay, s/veh												
LnGrp Delay(d),s/veh	22.1	20.2	16.3	19.9	28.4	22.8	46.2	46.2	48.2	45.1	0.0	75.5
LnGrp LOS	C	C	B	B	C	C	D	D	D	D	A	E
Approach Vol, veh/h		1135			883			177				356
Approach Delay, s/veh		20.5			27.3			47.0				65.7
Approach LOS		C			C			D				E
Timer - Assigned Phs		2	3	4		6	7	8				
Phs Duration (G+Y+Rc), s		22.6	9.0	63.6		24.8	19.8	52.8				
Change Period (Y+Rc), s		4.5	4.5	4.5		4.5	4.5	4.5				
Max Green Setting (Gmax), s		18.1	5.6	55.8		22.5	25.5	35.9				
Max Q Clear Time (g_c+I1), s		6.6	4.7	18.0		19.9	14.5	20.9				
Green Ext Time (p_c), s		0.4	0.0	6.3		0.4	0.8	4.8				
Intersection Summary												
HCM 6th Ctrl Delay			31.0									
HCM 6th LOS			C									
Notes												
User approved volume balancing among the lanes for turning movement.												

HCM 6th Signalized Intersection Summary
2: Dillon Ridge Road & US-6

2020 Total Saturday.syn
09/06/2018

												
Movement	EBL	EBT	EBR	WBL	WBT	WBR	NBL	NBT	NBR	SBL	SBT	SBR
Lane Configurations												
Traffic Volume (veh/h)	465	940	77	42	773	80	87	20	60	81	26	474
Future Volume (veh/h)	465	940	77	42	773	80	87	20	60	81	26	474
Initial Q (Qb), veh	0	0	0	0	0	0	0	0	0	0	0	0
Ped-Bike Adj(A_pbT)	1.00		1.00	1.00		1.00	1.00		1.00	1.00		1.00
Parking Bus, Adj	1.00	1.00	1.00	1.00	1.00	1.00	1.00	1.00	1.00	1.00	1.00	1.00
Work Zone On Approach		No			No			No			No	
Adj Sat Flow, veh/h/ln	1870	1870	1870	1870	1870	1870	1870	1870	1870	1870	1870	1870
Adj Flow Rate, veh/h	511	1044	68	56	878	68	132	0	50	108	37	90
Peak Hour Factor	0.91	0.90	0.77	0.75	0.88	0.81	0.75	0.88	0.71	0.75	0.71	0.82
Percent Heavy Veh, %	2	2	2	2	2	2	2	2	2	2	2	2
Cap, veh/h	557	2431	1084	391	2068	922	172	0	76	137	47	162
Arrive On Green	0.13	0.68	0.68	0.03	0.58	0.58	0.05	0.00	0.05	0.10	0.10	0.10
Sat Flow, veh/h	1781	3554	1585	1781	3554	1585	3563	0	1585	1343	460	1585
Grp Volume(v), veh/h	511	1044	68	56	878	68	132	0	50	145	0	90
Grp Sat Flow(s),veh/h/ln	1781	1777	1585	1781	1777	1585	1781	0	1585	1803	0	1585
Q Serve(g_s), s	14.6	17.7	1.9	1.7	18.5	2.5	4.9	0.0	4.2	10.6	0.0	7.3
Cycle Q Clear(g_c), s	14.6	17.7	1.9	1.7	18.5	2.5	4.9	0.0	4.2	10.6	0.0	7.3
Prop In Lane	1.00		1.00	1.00		1.00	1.00		1.00	0.74		1.00
Lane Grp Cap(c), veh/h	557	2431	1084	391	2068	922	172	0	76	184	0	162
V/C Ratio(X)	0.92	0.43	0.06	0.14	0.42	0.07	0.77	0.00	0.66	0.79	0.00	0.56
Avail Cap(c_a), veh/h	772	2431	1084	789	2068	922	172	0	76	621	0	546
HCM Platoon Ratio	1.00	1.00	1.00	1.00	1.00	1.00	1.00	1.00	1.00	1.00	1.00	1.00
Upstream Filter(I)	1.00	1.00	1.00	1.00	1.00	1.00	1.00	0.00	1.00	1.00	0.00	1.00
Uniform Delay (d), s/veh	15.4	9.5	7.0	10.4	15.7	12.3	63.5	0.0	63.1	59.2	0.0	57.7
Incr Delay (d2), s/veh	12.6	0.6	0.1	0.2	0.6	0.2	27.7	0.0	36.3	7.3	0.0	3.0
Initial Q Delay(d3),s/veh	0.0	0.0	0.0	0.0	0.0	0.0	0.0	0.0	0.0	0.0	0.0	0.0
%ile BackOfQ(50%),veh/ln	11.9	6.8	0.7	0.7	7.6	0.9	2.9	0.0	2.5	5.2	0.0	3.1
Unsig. Movement Delay, s/veh												
LnGrp Delay(d),s/veh	28.0	10.1	7.2	10.6	16.3	12.5	91.2	0.0	99.5	66.5	0.0	60.7
LnGrp LOS	C	B	A	B	B	B	F	A	F	E	A	E
Approach Vol, veh/h		1623			1002			182			235	
Approach Delay, s/veh		15.6			15.7			93.4			64.3	
Approach LOS		B			B			F			E	
Timer - Assigned Phs		2	3	4		6	7	8				
Phs Duration (G+Y+Rc), s		11.0	8.9	96.8		18.3	22.7	83.1				
Change Period (Y+Rc), s		4.5	4.5	4.5		4.5	4.5	4.5				
Max Green Setting (Gmax), s		6.5	34.5	29.5		46.5	34.5	29.5				
Max Q Clear Time (g_c+I1), s		6.9	3.7	19.7		12.6	16.6	20.5				
Green Ext Time (p_c), s		0.0	0.1	5.2		1.2	1.6	4.1				
Intersection Summary												
HCM 6th Ctrl Delay			24.1									
HCM 6th LOS			C									
Notes												
User approved pedestrian interval to be less than phase max green.												
User approved volume balancing among the lanes for turning movement.												

HCM 6th Signalized Intersection Summary
 2: Dillon Ridge Road & US-6

2040 BG AM.syn
 08/29/2018

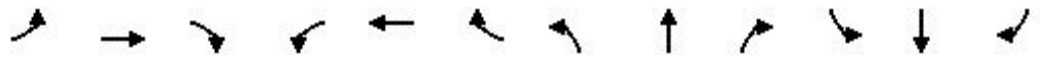

Movement	EBL	EBT	EBR	WBL	WBT	WBR	NBL	NBT	NBR	SBL	SBT	SBR
Lane Configurations	↖	↗	↘	↖	↗	↘	↖	↗	↘		↖	↘
Traffic Volume (veh/h)	129	749	23	14	719	29	20	5	10	15	0	125
Future Volume (veh/h)	129	749	23	14	719	29	20	5	10	15	0	125
Initial Q (Qb), veh	0	0	0	0	0	0	0	0	0	0	0	0
Ped-Bike Adj(A_pbT)	1.00		1.00	1.00		1.00	1.00		1.00	1.00		1.00
Parking Bus, Adj	1.00	1.00	1.00	1.00	1.00	1.00	1.00	1.00	1.00	1.00	1.00	1.00
Work Zone On Approach		No			No			No			No	
Adj Sat Flow, veh/h/ln	1870	1870	1870	1870	1870	1870	1870	1870	1870	1870	1870	1870
Adj Flow Rate, veh/h	193	823	44	20	765	44	22	26	12	24	0	149
Peak Hour Factor	0.67	0.91	0.52	0.70	0.94	0.66	0.62	0.42	0.83	0.62	0.92	0.84
Percent Heavy Veh, %	2	2	2	2	2	2	2	2	2	2	2	2
Cap, veh/h	517	2458	1096	470	2382	1063	139	145	123	139	0	123
Arrive On Green	0.04	0.69	0.69	0.02	0.67	0.67	0.08	0.08	0.08	0.08	0.00	0.08
Sat Flow, veh/h	1781	3554	1585	1781	3554	1585	1781	1870	1585	1781	0	1585
Grp Volume(v), veh/h	193	823	44	20	765	44	22	26	12	24	0	149
Grp Sat Flow(s),veh/h/ln	1781	1777	1585	1781	1777	1585	1781	1870	1585	1781	0	1585
Q Serve(g_s), s	4.7	12.5	1.2	0.5	12.2	1.3	1.6	1.8	0.9	1.7	0.0	10.5
Cycle Q Clear(g_c), s	4.7	12.5	1.2	0.5	12.2	1.3	1.6	1.8	0.9	1.7	0.0	10.5
Prop In Lane	1.00		1.00	1.00		1.00	1.00		1.00	1.00		1.00
Lane Grp Cap(c), veh/h	517	2458	1096	470	2382	1063	139	145	123	139	0	123
V/C Ratio(X)	0.37	0.33	0.04	0.04	0.32	0.04	0.16	0.18	0.10	0.17	0.00	1.21
Avail Cap(c_a), veh/h	517	2458	1096	508	2382	1063	139	145	123	139	0	123
HCM Platoon Ratio	1.00	1.00	1.00	1.00	1.00	1.00	1.00	1.00	1.00	1.00	1.00	1.00
Upstream Filter(I)	1.00	1.00	1.00	1.00	1.00	1.00	1.00	1.00	1.00	1.00	0.00	1.00
Uniform Delay (d), s/veh	7.0	8.4	6.6	6.9	9.3	7.5	58.1	58.2	57.8	58.2	0.0	62.3
Incr Delay (d2), s/veh	0.4	0.4	0.1	0.0	0.4	0.1	2.4	2.7	1.6	0.6	0.0	147.7
Initial Q Delay(d3),s/veh	0.0	0.0	0.0	0.0	0.0	0.0	0.0	0.0	0.0	0.0	0.0	0.0
%ile BackOfQ(50%),veh/ln	1.8	4.8	0.4	0.2	4.7	0.4	0.8	0.9	0.4	0.8	0.0	9.3
Unsig. Movement Delay, s/veh												
LnGrp Delay(d),s/veh	7.5	8.7	6.7	7.0	9.7	7.6	60.6	60.9	59.4	58.8	0.0	209.9
LnGrp LOS	A	A	A	A	A	A	E	E	E	E	A	F
Approach Vol, veh/h		1060			829			60			173	
Approach Delay, s/veh		8.4			9.5			60.5			188.9	
Approach LOS		A			A			E			F	
Timer - Assigned Phs		2	3	4		6	7	8				
Phs Duration (G+Y+Rc), s		15.0	7.1	97.9		15.0	10.0	95.0				
Change Period (Y+Rc), s		4.5	4.5	4.5		4.5	4.5	4.5				
Max Green Setting (Gmax), s		10.5	5.5	90.5		10.5	5.5	90.5				
Max Q Clear Time (g_c+I1), s		3.8	2.5	14.5		12.5	6.7	14.2				
Green Ext Time (p_c), s		0.1	0.0	7.4		0.0	0.0	6.7				

Intersection Summary

HCM 6th Ctrl Delay	25.0
HCM 6th LOS	C

Notes

- User approved pedestrian interval to be less than phase max green.
- User approved volume balancing among the lanes for turning movement.

HCM 6th Signalized Intersection Summary
2: Dillon Ridge Road & US-6

2040 BG PM.syn
08/29/2018

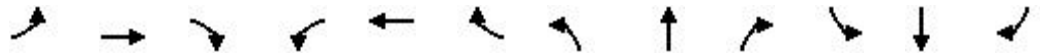

Movement	EBL	EBT	EBR	WBL	WBT	WBR	NBL	NBT	NBR	SBL	SBT	SBR
Lane Configurations	↖	↗	↘	↖	↗	↘	↖	↗	↘		↖	↗
Traffic Volume (veh/h)	272	935	49	48	960	29	57	31	49	28	9	313
Future Volume (veh/h)	272	935	49	48	960	29	57	31	49	28	9	313
Initial Q (Qb), veh	0	0	0	0	0	0	0	0	0	0	0	0
Ped-Bike Adj(A_pbT)	1.00		1.00	1.00		1.00	1.00		1.00	1.00		1.00
Parking Bus, Adj	1.00	1.00	1.00	1.00	1.00	1.00	1.00	1.00	1.00	1.00	1.00	1.00
Work Zone On Approach		No			No			No			No	
Adj Sat Flow, veh/h/ln	1870	1870	1870	1870	1870	1870	1870	1870	1870	1870	1870	1870
Adj Flow Rate, veh/h	292	995	64	68	1000	40	50	56	68	56	12	234
Peak Hour Factor	0.93	0.94	0.77	0.71	0.96	0.72	0.89	0.86	0.72	0.50	0.75	0.95
Percent Heavy Veh, %	2	2	2	2	2	2	2	2	2	2	2	2
Cap, veh/h	370	1801	803	294	1547	690	267	281	238	231	49	247
Arrive On Green	0.11	0.51	0.51	0.04	0.44	0.44	0.15	0.15	0.15	0.16	0.16	0.16
Sat Flow, veh/h	1781	3554	1585	1781	3554	1585	1781	1870	1585	1479	317	1585
Grp Volume(v), veh/h	292	995	64	68	1000	40	50	56	68	68	0	234
Grp Sat Flow(s),veh/h/ln	1781	1777	1585	1781	1777	1585	1781	1870	1585	1796	0	1585
Q Serve(g_s), s	10.3	23.0	2.5	2.5	26.5	1.8	2.9	3.1	4.6	4.0	0.0	17.5
Cycle Q Clear(g_c), s	10.3	23.0	2.5	2.5	26.5	1.8	2.9	3.1	4.6	4.0	0.0	17.5
Prop In Lane	1.00		1.00	1.00		1.00	1.00		1.00	0.82		1.00
Lane Grp Cap(c), veh/h	370	1801	803	294	1547	690	267	281	238	280	0	247
V/C Ratio(X)	0.79	0.55	0.08	0.23	0.65	0.06	0.19	0.20	0.29	0.24	0.00	0.95
Avail Cap(c_a), veh/h	570	1801	803	339	1547	690	267	281	238	280	0	247
HCM Platoon Ratio	1.00	1.00	1.00	1.00	1.00	1.00	1.00	1.00	1.00	1.00	1.00	1.00
Upstream Filter(l)	1.00	1.00	1.00	1.00	1.00	1.00	1.00	1.00	1.00	1.00	0.00	1.00
Uniform Delay (d), s/veh	21.0	20.3	15.2	18.3	26.6	19.6	44.6	44.7	45.3	44.4	0.0	50.2
Incr Delay (d2), s/veh	4.1	1.2	0.2	0.4	2.1	0.2	1.5	1.6	3.0	0.4	0.0	42.8
Initial Q Delay(d3),s/veh	0.0	0.0	0.0	0.0	0.0	0.0	0.0	0.0	0.0	0.0	0.0	0.0
%ile BackOfQ(50%),veh/ln	4.5	9.7	0.9	1.1	11.5	0.7	1.4	1.6	2.0	1.8	0.0	9.9
Unsig. Movement Delay, s/veh												
LnGrp Delay(d),s/veh	25.1	21.5	15.4	18.7	28.7	19.8	46.1	46.3	48.3	44.9	0.0	93.0
LnGrp LOS	C	C	B	B	C	B	D	D	D	D	A	F
Approach Vol, veh/h		1351			1108			174				302
Approach Delay, s/veh		22.0			27.8			47.0				82.2
Approach LOS		C			C			D				F
Timer - Assigned Phs		2	3	4		6	7	8				
Phs Duration (G+Y+Rc), s		22.5	9.0	65.3		23.2	17.6	56.7				
Change Period (Y+Rc), s		4.5	4.5	4.5		4.5	4.5	4.5				
Max Green Setting (Gmax), s		18.0	7.5	57.8		18.7	26.5	38.8				
Max Q Clear Time (g_c+1), s		6.6	4.5	25.0		19.5	12.3	28.5				
Green Ext Time (p_c), s		0.4	0.0	8.9		0.0	0.7	5.1				
Intersection Summary												
HCM 6th Ctrl Delay				31.9								
HCM 6th LOS				C								
Notes												
User approved volume balancing among the lanes for turning movement.												

HCM 6th Signalized Intersection Summary
 2: Dillon Ridge Road & US-6

2040 BG Saturday.syn
 09/06/2018



Movement	EBL	EBT	EBR	WBL	WBT	WBR	NBL	NBT	NBR	SBL	SBT	SBR
Lane Configurations												
Traffic Volume (veh/h)	402	1265	77	42	1041	42	87	14	60	45	20	413
Future Volume (veh/h)	402	1265	77	42	1041	42	87	14	60	45	20	413
Initial Q (Qb), veh	0	0	0	0	0	0	0	0	0	0	0	0
Ped-Bike Adj(A_pbT)	1.00		1.00	1.00		1.00	1.00		1.00	1.00		1.00
Parking Bus, Adj	1.00	1.00	1.00	1.00	1.00	1.00	1.00	1.00	1.00	1.00	1.00	1.00
Work Zone On Approach		No			No			No			No	
Adj Sat Flow, veh/h/ln	1870	1870	1870	1870	1870	1870	1870	1870	1870	1870	1870	1870
Adj Flow Rate, veh/h	442	1406	68	56	1183	21	127	0	50	60	28	16
Peak Hour Factor	0.91	0.90	0.77	0.75	0.88	0.81	0.75	0.88	0.71	0.75	0.71	0.82
Percent Heavy Veh, %	2	2	2	2	2	2	2	2	2	2	2	2
Cap, veh/h	470	2560	1142	304	2267	1011	172	0	76	81	38	104
Arrive On Green	0.11	0.72	0.72	0.03	0.64	0.64	0.05	0.00	0.05	0.07	0.07	0.07
Sat Flow, veh/h	1781	3554	1585	1781	3554	1585	3563	0	1585	1233	575	1585
Grp Volume(v), veh/h	442	1406	68	56	1183	21	127	0	50	88	0	16
Grp Sat Flow(s),veh/h/ln	1781	1777	1585	1781	1777	1585	1781	0	1585	1809	0	1585
Q Serve(g_s), s	12.6	24.7	1.7	1.4	24.4	0.7	4.8	0.0	4.2	6.5	0.0	1.3
Cycle Q Clear(g_c), s	12.6	24.7	1.7	1.4	24.4	0.7	4.8	0.0	4.2	6.5	0.0	1.3
Prop In Lane	1.00		1.00	1.00		1.00	1.00		1.00	0.68		1.00
Lane Grp Cap(c), veh/h	470	2560	1142	304	2267	1011	172	0	76	119	0	104
V/C Ratio(X)	0.94	0.55	0.06	0.18	0.52	0.02	0.74	0.00	0.66	0.74	0.00	0.15
Avail Cap(c_a), veh/h	549	2560	1142	530	2267	1011	172	0	76	931	0	816
HCM Platoon Ratio	1.00	1.00	1.00	1.00	1.00	1.00	1.00	1.00	1.00	1.00	1.00	1.00
Upstream Filter(I)	1.00	1.00	1.00	1.00	1.00	1.00	1.00	0.00	1.00	1.00	0.00	1.00
Uniform Delay (d), s/veh	21.0	8.7	5.5	8.4	13.3	9.0	63.4	0.0	63.1	61.9	0.0	59.5
Incr Delay (d2), s/veh	22.5	0.9	0.1	0.3	0.9	0.0	24.7	0.0	36.3	8.8	0.0	0.7
Initial Q Delay(d3),s/veh	0.0	0.0	0.0	0.0	0.0	0.0	0.0	0.0	0.0	0.0	0.0	0.0
%ile BackOfQ(50%),veh/ln	12.5	9.1	0.6	0.6	9.8	0.2	2.7	0.0	2.5	3.3	0.0	0.5
Unsig. Movement Delay, s/veh												
LnGrp Delay(d),s/veh	43.5	9.6	5.6	8.7	14.1	9.0	88.1	0.0	99.5	70.7	0.0	60.2
LnGrp LOS	D	A	A	A	B	A	F	A	F	E	A	E
Approach Vol, veh/h		1916			1260			177			104	
Approach Delay, s/veh		17.3			13.8			91.3			69.1	
Approach LOS		B			B			F			E	
Timer - Assigned Phs		2	3	4		6	7	8				
Phs Duration (G+Y+Rc), s		11.0	8.9	101.8		13.4	20.0	90.6				
Change Period (Y+Rc), s		4.5	4.5	4.5		4.5	4.5	4.5				
Max Green Setting (Gmax), s		6.5	21.5	19.5		69.5	21.5	19.5				
Max Q Clear Time (g_c+I1), s		6.8	3.4	26.7		8.5	14.6	26.4				
Green Ext Time (p_c), s		0.0	0.1	0.0		0.6	0.9	0.0				

Intersection Summary

HCM 6th Ctrl Delay	21.4
HCM 6th LOS	C

Notes

- User approved pedestrian interval to be less than phase max green.
- User approved volume balancing among the lanes for turning movement.

HCM 6th Signalized Intersection Summary
 2: Dillon Ridge Road & US-6

2040 Total AM.syn
 09/05/2018

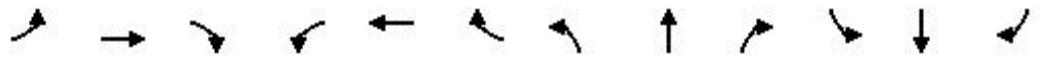

Movement	EBL	EBT	EBR	WBL	WBT	WBR	NBL	NBT	NBR	SBL	SBT	SBR
Lane Configurations	↖	↗	↘	↖	↗	↘	↖	↗	↘		↖	↗
Traffic Volume (veh/h)	175	749	23	14	719	57	20	10	10	42	4	170
Future Volume (veh/h)	175	749	23	14	719	57	20	10	10	42	4	170
Initial Q (Qb), veh	0	0	0	0	0	0	0	0	0	0	0	0
Ped-Bike Adj(A_pbT)	1.00		1.00	1.00		1.00	1.00		1.00	1.00		1.00
Parking Bus, Adj	1.00	1.00	1.00	1.00	1.00	1.00	1.00	1.00	1.00	1.00	1.00	1.00
Work Zone On Approach		No			No			No			No	
Adj Sat Flow, veh/h/ln	1870	1870	1870	1870	1870	1870	1870	1870	1870	1870	1870	1870
Adj Flow Rate, veh/h	261	823	44	20	765	86	28	30	12	68	4	184
Peak Hour Factor	0.67	0.91	0.52	0.70	0.94	0.66	0.62	0.42	0.83	0.62	0.92	0.84
Percent Heavy Veh, %	2	2	2	2	2	2	2	2	2	2	2	2
Cap, veh/h	502	2458	1096	470	2382	1063	99	104	88	169	10	159
Arrive On Green	0.04	0.69	0.69	0.02	0.67	0.67	0.06	0.06	0.06	0.10	0.10	0.10
Sat Flow, veh/h	1781	3554	1585	1781	3554	1585	1781	1870	1585	1687	99	1585
Grp Volume(v), veh/h	261	823	44	20	765	86	28	30	12	72	0	184
Grp Sat Flow(s),veh/h/ln	1781	1777	1585	1781	1777	1585	1781	1870	1585	1786	0	1585
Q Serve(g_s), s	5.5	12.5	1.2	0.5	12.2	2.6	2.0	2.1	1.0	5.1	0.0	13.5
Cycle Q Clear(g_c), s	5.5	12.5	1.2	0.5	12.2	2.6	2.0	2.1	1.0	5.1	0.0	13.5
Prop In Lane	1.00		1.00	1.00		1.00	1.00		1.00	0.94		1.00
Lane Grp Cap(c), veh/h	502	2458	1096	470	2382	1063	99	104	88	179	0	159
V/C Ratio(X)	0.52	0.33	0.04	0.04	0.32	0.08	0.28	0.29	0.14	0.40	0.00	1.16
Avail Cap(c_a), veh/h	502	2458	1096	508	2382	1063	99	104	88	179	0	159
HCM Platoon Ratio	1.00	1.00	1.00	1.00	1.00	1.00	1.00	1.00	1.00	1.00	1.00	1.00
Upstream Filter(I)	1.00	1.00	1.00	1.00	1.00	1.00	1.00	1.00	1.00	1.00	0.00	1.00
Uniform Delay (d), s/veh	8.6	8.4	6.6	6.9	9.3	7.8	61.2	61.2	60.7	57.0	0.0	60.8
Incr Delay (d2), s/veh	1.0	0.4	0.1	0.0	0.4	0.1	7.0	6.9	3.2	1.5	0.0	121.3
Initial Q Delay(d3),s/veh	0.0	0.0	0.0	0.0	0.0	0.0	0.0	0.0	0.0	0.0	0.0	0.0
%ile BackOfQ(50%),veh/ln	2.5	4.8	0.4	0.2	4.7	0.9	1.1	1.2	0.5	2.4	0.0	10.8
Unsig. Movement Delay, s/veh												
LnGrp Delay(d),s/veh	9.5	8.7	6.7	7.0	9.7	7.9	68.2	68.1	63.9	58.4	0.0	182.0
LnGrp LOS	A	A	A	A	A	A	E	E	E	E	A	F
Approach Vol, veh/h		1128			871			70			256	
Approach Delay, s/veh		8.8			9.5			67.4			147.3	
Approach LOS		A			A			E			F	
Timer - Assigned Phs		2	3	4		6	7	8				
Phs Duration (G+Y+Rc), s		12.0	7.1	97.9		18.0	10.0	95.0				
Change Period (Y+Rc), s		4.5	4.5	4.5		4.5	4.5	4.5				
Max Green Setting (Gmax), s		7.5	5.5	90.5		13.5	5.5	90.5				
Max Q Clear Time (g_c+I1), s		4.1	2.5	14.5		15.5	7.5	14.2				
Green Ext Time (p_c), s		0.0	0.0	7.4		0.0	0.0	6.9				

Intersection Summary

HCM 6th Ctrl Delay	26.1
HCM 6th LOS	C

Notes

- User approved pedestrian interval to be less than phase max green.
- User approved volume balancing among the lanes for turning movement.

HCM 6th Signalized Intersection Summary
2: Dillon Ridge Road & US-6

2040 Total PM.syn
09/05/2018

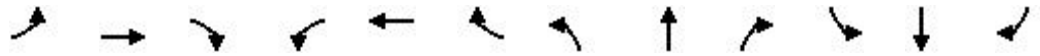

Movement	EBL	EBT	EBR	WBL	WBT	WBR	NBL	NBT	NBR	SBL	SBT	SBR
Lane Configurations												
Traffic Volume (veh/h)	310	935	49	48	960	52	57	35	49	49	13	349
Future Volume (veh/h)	310	935	49	48	960	52	57	35	49	49	13	349
Initial Q (Qb), veh	0	0	0	0	0	0	0	0	0	0	0	0
Ped-Bike Adj(A_pbT)	1.00		1.00	1.00		1.00	1.00		1.00	1.00		1.00
Parking Bus, Adj	1.00	1.00	1.00	1.00	1.00	1.00	1.00	1.00	1.00	1.00	1.00	1.00
Work Zone On Approach		No			No			No			No	
Adj Sat Flow, veh/h/ln	1870	1870	1870	1870	1870	1870	1870	1870	1870	1870	1870	1870
Adj Flow Rate, veh/h	333	995	64	68	1000	72	52	57	68	98	17	272
Peak Hour Factor	0.93	0.94	0.77	0.71	0.96	0.72	0.89	0.86	0.72	0.50	0.75	0.95
Percent Heavy Veh, %	2	2	2	2	2	2	2	2	2	2	2	2
Cap, veh/h	386	1825	814	299	1520	678	200	210	178	285	49	296
Arrive On Green	0.12	0.51	0.51	0.04	0.43	0.43	0.11	0.11	0.11	0.19	0.19	0.19
Sat Flow, veh/h	1781	3554	1585	1781	3554	1585	1781	1870	1585	1529	265	1585
Grp Volume(v), veh/h	333	995	64	68	1000	72	52	57	68	115	0	272
Grp Sat Flow(s),veh/h/ln	1781	1777	1585	1781	1777	1585	1781	1870	1585	1794	0	1585
Q Serve(g_s), s	11.9	22.7	2.5	2.5	26.9	3.3	3.2	3.3	4.8	6.7	0.0	20.2
Cycle Q Clear(g_c), s	11.9	22.7	2.5	2.5	26.9	3.3	3.2	3.3	4.8	6.7	0.0	20.2
Prop In Lane	1.00		1.00	1.00		1.00	1.00		1.00	0.85		1.00
Lane Grp Cap(c), veh/h	386	1825	814	299	1520	678	200	210	178	335	0	296
V/C Ratio(X)	0.86	0.55	0.08	0.23	0.66	0.11	0.26	0.27	0.38	0.34	0.00	0.92
Avail Cap(c_a), veh/h	561	1825	814	344	1520	678	200	210	178	347	0	306
HCM Platoon Ratio	1.00	1.00	1.00	1.00	1.00	1.00	1.00	1.00	1.00	1.00	1.00	1.00
Upstream Filter(I)	1.00	1.00	1.00	1.00	1.00	1.00	1.00	1.00	1.00	1.00	0.00	1.00
Uniform Delay (d), s/veh	21.7	19.7	14.8	18.6	27.3	20.6	48.7	48.7	49.4	42.4	0.0	47.9
Incr Delay (d2), s/veh	9.2	1.2	0.2	0.4	2.2	0.3	3.1	3.1	6.1	0.6	0.0	30.9
Initial Q Delay(d3),s/veh	0.0	0.0	0.0	0.0	0.0	0.0	0.0	0.0	0.0	0.0	0.0	0.0
%ile BackOfQ(50%),veh/ln	5.7	9.5	0.9	1.1	11.7	1.3	1.6	1.8	2.2	3.0	0.0	10.5
Unsig. Movement Delay, s/veh												
LnGrp Delay(d),s/veh	30.9	20.9	15.0	19.0	29.6	20.9	51.8	51.9	55.5	43.0	0.0	78.8
LnGrp LOS	C	C	B	B	C	C	D	D	E	D	A	E
Approach Vol, veh/h		1392			1140			177				387
Approach Delay, s/veh		23.0			28.4			53.2				68.2
Approach LOS		C			C			D				E
Timer - Assigned Phs		2	3	4		6	7	8				
Phs Duration (G+Y+Rc), s		18.0	9.0	66.1		26.9	19.3	55.8				
Change Period (Y+Rc), s		4.5	4.5	4.5		4.5	4.5	4.5				
Max Green Setting (Gmax), s		13.5	7.5	57.8		23.2	26.5	38.8				
Max Q Clear Time (g_c+l1), s		6.8	4.5	24.7		22.2	13.9	28.9				
Green Ext Time (p_c), s		0.3	0.0	9.0		0.2	0.8	5.0				

Intersection Summary

HCM 6th Ctrl Delay	32.4
HCM 6th LOS	C

Notes

- User approved pedestrian interval to be less than phase max green.
- User approved volume balancing among the lanes for turning movement.

HCM 6th Signalized Intersection Summary
 2: Dillon Ridge Road & US-6

2040 Total Saturday.syn
 09/06/2018

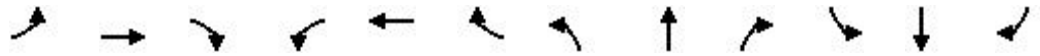

Movement	EBL	EBT	EBR	WBL	WBT	WBR	NBL	NBT	NBR	SBL	SBT	SBR
Lane Configurations	↘	↗↗	↘	↘	↗↗	↘	↘	↗	↘		↗	↘
Traffic Volume (veh/h)	465	1265	77	42	1041	80	87	20	60	81	26	474
Future Volume (veh/h)	465	1265	77	42	1041	80	87	20	60	81	26	474
Initial Q (Qb), veh	0	0	0	0	0	0	0	0	0	0	0	0
Ped-Bike Adj(A_pbT)	1.00		1.00	1.00		1.00	1.00		1.00	1.00		1.00
Parking Bus, Adj	1.00	1.00	1.00	1.00	1.00	1.00	1.00	1.00	1.00	1.00	1.00	1.00
Work Zone On Approach		No			No			No			No	
Adj Sat Flow, veh/h/ln	1870	1870	1870	1870	1870	1870	1870	1870	1870	1870	1870	1870
Adj Flow Rate, veh/h	511	1406	35	56	1183	37	132	0	15	108	37	90
Peak Hour Factor	0.91	0.90	0.77	0.75	0.88	0.81	0.75	0.88	0.71	0.75	0.71	0.82
Percent Heavy Veh, %	2	2	2	2	2	2	2	2	2	2	2	2
Cap, veh/h	532	2430	1084	288	1845	823	172	0	76	137	47	162
Arrive On Green	0.20	0.68	0.68	0.03	0.52	0.52	0.05	0.00	0.05	0.10	0.10	0.10
Sat Flow, veh/h	1781	3554	1585	1781	3554	1585	3563	0	1585	1343	460	1585
Grp Volume(v), veh/h	511	1406	35	56	1183	37	132	0	15	145	0	90
Grp Sat Flow(s),veh/h/ln	1781	1777	1585	1781	1777	1585	1781	0	1585	1803	0	1585
Q Serve(g_s), s	24.4	27.9	1.0	2.0	32.4	1.6	4.9	0.0	1.2	10.6	0.0	7.3
Cycle Q Clear(g_c), s	24.4	27.9	1.0	2.0	32.4	1.6	4.9	0.0	1.2	10.6	0.0	7.3
Prop In Lane	1.00		1.00	1.00		1.00	1.00		1.00	0.74		1.00
Lane Grp Cap(c), veh/h	532	2430	1084	288	1845	823	172	0	76	184	0	162
V/C Ratio(X)	0.96	0.58	0.03	0.19	0.64	0.04	0.77	0.00	0.20	0.79	0.00	0.56
Avail Cap(c_a), veh/h	544	2430	1084	593	1845	823	172	0	76	821	0	722
HCM Platoon Ratio	1.00	1.00	1.00	1.00	1.00	1.00	1.00	1.00	1.00	1.00	1.00	1.00
Upstream Filter(I)	1.00	1.00	1.00	1.00	1.00	1.00	1.00	0.00	1.00	1.00	0.00	1.00
Uniform Delay (d), s/veh	31.4	11.2	6.9	14.1	23.4	16.0	63.5	0.0	61.7	59.2	0.0	57.7
Incr Delay (d2), s/veh	28.5	1.0	0.1	0.3	1.7	0.1	27.7	0.0	5.7	7.2	0.0	3.0
Initial Q Delay(d3),s/veh	0.0	0.0	0.0	0.0	0.0	0.0	0.0	0.0	0.0	0.0	0.0	0.0
%ile BackOfQ(50%),veh/ln	21.0	10.8	0.3	0.8	13.9	0.6	2.9	0.0	0.6	5.2	0.0	3.1
Unsig. Movement Delay, s/veh												
LnGrp Delay(d),s/veh	59.9	12.2	7.0	14.5	25.1	16.1	91.2	0.0	67.4	66.4	0.0	60.6
LnGrp LOS	E	B	A	B	C	B	F	A	E	E	A	E
Approach Vol, veh/h		1952			1276			147				235
Approach Delay, s/veh		24.6			24.4			88.7				64.2
Approach LOS		C			C			F				E
Timer - Assigned Phs		2	3	4		6	7	8				
Phs Duration (G+Y+Rc), s		11.0	8.9	96.8		18.3	31.1	74.6				
Change Period (Y+Rc), s		4.5	4.5	4.5		4.5	4.5	4.5				
Max Green Setting (Gmax), s		6.5	27.5	21.5		61.5	27.5	21.5				
Max Q Clear Time (g_c+I1), s		6.9	4.0	29.9		12.6	26.4	34.4				
Green Ext Time (p_c), s		0.0	0.1	0.0		1.2	0.2	0.0				
Intersection Summary												
HCM 6th Ctrl Delay			29.7									
HCM 6th LOS			C									
Notes												
User approved pedestrian interval to be less than phase max green.												
User approved volume balancing among the lanes for turning movement.												

APPENDIX E

Queueing Analysis Worksheets

Queues
2: Dillon Ridge Road & US-6

2018 Existing AM.syn
07/30/2018



Lane Group	EBL	EBT	EBR	WBL	WBT	WBR	NBL	NBT	NBR	SBT	SBR
Lane Group Flow (vph)	193	593	44	20	551	44	22	22	12	24	149
v/c Ratio	0.31	0.23	0.04	0.03	0.23	0.04	0.17	0.16	0.06	0.24	0.65
Control Delay	5.8	7.2	0.2	4.4	8.7	0.2	61.5	61.4	0.6	65.9	22.7
Queue Delay	0.0	0.0	0.0	0.0	0.0	0.0	0.0	0.0	0.0	0.0	0.0
Total Delay	5.8	7.2	0.2	4.4	8.7	0.2	61.5	61.4	0.6	65.9	22.7
Queue Length 50th (ft)	38	92	0	4	92	0	18	18	0	21	0
Queue Length 95th (ft)	47	127	0	8	117	0	33	23	0	50	55
Internal Link Dist (ft)		740			733			315		111	
Turn Bay Length (ft)	300		150	600		450	60		60		120
Base Capacity (vph)	629	2549	1163	614	2396	1099	130	134	201	137	260
Starvation Cap Reductn	0	0	0	0	0	0	0	0	0	0	0
Spillback Cap Reductn	0	0	0	0	0	0	0	0	0	0	0
Storage Cap Reductn	0	0	0	0	0	0	0	0	0	0	0
Reduced v/c Ratio	0.31	0.23	0.04	0.03	0.23	0.04	0.17	0.16	0.06	0.18	0.57

Intersection Summary

Queues
2: Dillon Ridge Road & US-6

2018 Existing PM.syn
07/30/2018



Lane Group	EBL	EBT	EBR	WBL	WBT	WBR	NBL	NBT	NBR	SBT	SBR
Lane Group Flow (vph)	292	717	64	68	721	40	49	51	68	68	329
v/c Ratio	0.54	0.32	0.06	0.14	0.37	0.04	0.33	0.34	0.26	0.42	0.74
Control Delay	10.7	11.9	1.1	7.7	17.0	0.1	58.2	58.0	2.4	57.7	16.0
Queue Delay	0.0	0.0	0.0	0.0	0.0	0.0	0.0	0.0	0.0	0.0	0.0
Total Delay	10.7	11.9	1.1	7.7	17.0	0.1	58.2	58.0	2.4	57.7	16.0
Queue Length 50th (ft)	68	128	0	14	147	0	37	40	0	51	0
Queue Length 95th (ft)	130	205	4	27	263	0	80	78	0	76	86
Internal Link Dist (ft)		740			733			315		111	
Turn Bay Length (ft)	300		150	600		450	60		60		120
Base Capacity (vph)	770	2229	1032	655	1969	941	147	152	262	269	518
Starvation Cap Reductn	0	0	0	0	0	0	0	0	0	0	0
Spillback Cap Reductn	0	0	0	0	0	0	0	0	0	0	0
Storage Cap Reductn	0	0	0	0	0	0	0	0	0	0	0
Reduced v/c Ratio	0.38	0.32	0.06	0.10	0.37	0.04	0.33	0.34	0.26	0.25	0.64

Intersection Summary

Queues
2: Dillon Ridge Road & US-6

2018 Existing Saturday.syn
09/06/2018



Lane Group	EBL	EBT	EBR	WBL	WBT	WBR	NBL	NBT	NBR	SBT	SBR
Lane Group Flow (vph)	442	1013	100	56	852	52	66	66	85	88	504
v/c Ratio	0.65	0.43	0.09	0.18	0.59	0.07	0.82	0.80	0.54	0.44	0.81
Control Delay	21.8	12.5	3.5	11.7	32.8	1.8	123.3	118.7	25.6	60.7	15.6
Queue Delay	0.0	0.0	0.0	0.0	0.0	0.0	0.0	0.0	0.0	0.0	0.0
Total Delay	21.8	12.5	3.5	11.7	32.8	1.8	123.3	118.7	25.6	60.7	15.6
Queue Length 50th (ft)	172	197	4	11	263	0	61	61	0	75	3
Queue Length 95th (ft)	351	347	23	28	393	4	#115	#149	27	90	52
Internal Link Dist (ft)		740			733			315		111	
Turn Bay Length (ft)	300		150	600		450	60		60		120
Base Capacity (vph)	676	2374	1089	498	1456	701	80	82	157	927	1057
Starvation Cap Reductn	0	0	0	0	0	0	0	0	0	0	0
Spillback Cap Reductn	0	0	0	0	0	0	0	0	0	0	0
Storage Cap Reductn	0	0	0	0	0	0	0	0	0	0	0
Reduced v/c Ratio	0.65	0.43	0.09	0.11	0.59	0.07	0.82	0.80	0.54	0.09	0.48

Intersection Summary

95th percentile volume exceeds capacity, queue may be longer.
Queue shown is maximum after two cycles.

Queues
2: Dillon Ridge Road & US-6

2020 BG AM.syn
09/05/2018



Lane Group	EBL	EBT	EBR	WBL	WBT	WBR	NBL	NBT	NBR	SBT	SBR
Lane Group Flow (vph)	193	611	44	20	568	44	22	22	12	24	149
v/c Ratio	0.31	0.24	0.04	0.03	0.24	0.04	0.17	0.16	0.06	0.24	0.65
Control Delay	5.9	7.3	0.2	4.4	8.8	0.2	61.5	61.4	0.6	65.9	22.7
Queue Delay	0.0	0.0	0.0	0.0	0.0	0.0	0.0	0.0	0.0	0.0	0.0
Total Delay	5.9	7.3	0.2	4.4	8.8	0.2	61.5	61.4	0.6	65.9	22.7
Queue Length 50th (ft)	38	95	0	4	95	0	18	18	0	21	0
Queue Length 95th (ft)	47	131	0	8	121	0	33	23	0	50	55
Internal Link Dist (ft)		740			733			315		111	
Turn Bay Length (ft)	300		150	600		450	60		60		120
Base Capacity (vph)	618	2549	1163	604	2396	1099	130	134	201	137	260
Starvation Cap Reductn	0	0	0	0	0	0	0	0	0	0	0
Spillback Cap Reductn	0	0	0	0	0	0	0	0	0	0	0
Storage Cap Reductn	0	0	0	0	0	0	0	0	0	0	0
Reduced v/c Ratio	0.31	0.24	0.04	0.03	0.24	0.04	0.17	0.16	0.06	0.18	0.57

Intersection Summary

Queues
2: Dillon Ridge Road & US-6

2020 BG PM.syn
09/05/2018



Lane Group	EBL	EBT	EBR	WBL	WBT	WBR	NBL	NBT	NBR	SBT	SBR
Lane Group Flow (vph)	292	738	64	68	743	40	49	51	68	68	329
v/c Ratio	0.53	0.31	0.06	0.13	0.34	0.04	0.64	0.65	0.42	0.44	0.75
Control Delay	8.3	9.2	0.8	5.6	12.7	0.1	90.9	91.2	12.8	59.7	16.8
Queue Delay	0.0	0.0	0.0	0.0	0.0	0.0	0.0	0.0	0.0	0.0	0.0
Total Delay	8.3	9.2	0.8	5.6	12.7	0.1	90.9	91.2	12.8	59.7	16.8
Queue Length 50th (ft)	56	116	0	11	132	0	40	42	0	51	0
Queue Length 95th (ft)	103	177	3	21	224	0	#104	#100	5	78	89
Internal Link Dist (ft)		740			733			315		111	
Turn Bay Length (ft)	300		150	600		450	60		60		120
Base Capacity (vph)	877	2399	1103	939	2179	1011	77	79	163	230	490
Starvation Cap Reductn	0	0	0	0	0	0	0	0	0	0	0
Spillback Cap Reductn	0	0	0	0	0	0	0	0	0	0	0
Storage Cap Reductn	0	0	0	0	0	0	0	0	0	0	0
Reduced v/c Ratio	0.33	0.31	0.06	0.07	0.34	0.04	0.64	0.65	0.42	0.30	0.67

Intersection Summary

95th percentile volume exceeds capacity, queue may be longer.
Queue shown is maximum after two cycles.



Lane Group	EBL	EBT	EBR	WBL	WBT	WBR	NBL	NBT	NBR	SBT	SBR
Lane Group Flow (vph)	442	1044	100	56	878	52	66	66	85	88	504
v/c Ratio	0.66	0.44	0.09	0.19	0.60	0.07	0.82	0.80	0.54	0.44	0.81
Control Delay	23.4	12.7	3.5	11.8	33.3	1.8	123.3	118.7	25.6	60.7	15.6
Queue Delay	0.0	0.0	0.0	0.0	0.0	0.0	0.0	0.0	0.0	0.0	0.0
Total Delay	23.4	12.7	3.5	11.8	33.3	1.8	123.3	118.7	25.6	60.7	15.6
Queue Length 50th (ft)	184	205	4	11	273	0	61	61	0	75	3
Queue Length 95th (ft)	361	361	23	28	408	4	#115	#149	27	90	52
Internal Link Dist (ft)		740			733			315		111	
Turn Bay Length (ft)	300		150	600		450	60		60		120
Base Capacity (vph)	669	2374	1089	491	1456	701	80	82	157	927	1057
Starvation Cap Reductn	0	0	0	0	0	0	0	0	0	0	0
Spillback Cap Reductn	0	0	0	0	0	0	0	0	0	0	0
Storage Cap Reductn	0	0	0	0	0	0	0	0	0	0	0
Reduced v/c Ratio	0.66	0.44	0.09	0.11	0.60	0.07	0.82	0.80	0.54	0.09	0.48

Intersection Summary

95th percentile volume exceeds capacity, queue may be longer.
Queue shown is maximum after two cycles.

Queues
2: Dillon Ridge Road & US-6

2020 Total AM.syn
09/05/2018



Lane Group	EBL	EBT	EBR	WBL	WBT	WBR	NBL	NBT	NBR	SBT	SBR
Lane Group Flow (vph)	261	611	44	20	568	86	28	28	12	72	202
v/c Ratio	0.44	0.24	0.04	0.03	0.24	0.08	0.22	0.21	0.06	0.58	0.68
Control Delay	8.0	7.8	0.2	4.6	9.0	1.6	62.8	62.3	0.6	79.3	19.7
Queue Delay	0.0	0.0	0.0	0.0	0.0	0.0	0.0	0.0	0.0	0.0	0.0
Total Delay	8.0	7.8	0.2	4.6	9.0	1.6	62.8	62.3	0.6	79.3	19.7
Queue Length 50th (ft)	61	104	0	4	95	0	25	24	0	62	0
Queue Length 95th (ft)	62	131	0	8	121	6	40	27	0	115	59
Internal Link Dist (ft)		740			733			315		111	
Turn Bay Length (ft)	300		150	600		450	60		60		120
Base Capacity (vph)	599	2505	1145	590	2377	1091	130	136	201	138	309
Starvation Cap Reductn	0	0	0	0	0	0	0	0	0	0	0
Spillback Cap Reductn	0	0	0	0	0	0	0	0	0	0	0
Storage Cap Reductn	0	0	0	0	0	0	0	0	0	0	0
Reduced v/c Ratio	0.44	0.24	0.04	0.03	0.24	0.08	0.22	0.21	0.06	0.52	0.65

Intersection Summary



Lane Group	EBL	EBT	EBR	WBL	WBT	WBR	NBL	NBT	NBR	SBT	SBR
Lane Group Flow (vph)	333	738	64	68	743	72	52	53	68	115	367
v/c Ratio	0.69	0.39	0.07	0.17	0.49	0.09	0.21	0.20	0.19	0.56	0.72
Control Delay	19.5	18.0	1.5	12.9	28.3	0.2	47.1	46.9	1.2	59.5	13.5
Queue Delay	0.0	0.0	0.0	0.0	0.0	0.0	0.0	0.0	0.0	0.0	0.0
Total Delay	19.5	18.0	1.5	12.9	28.3	0.2	47.1	46.9	1.2	59.5	13.5
Queue Length 50th (ft)	113	175	0	20	212	0	37	37	0	85	0
Queue Length 95th (ft)	191	251	4	34	339	0	77	75	0	114	90
Internal Link Dist (ft)		740			733			315		111	
Turn Bay Length (ft)	300		150	600		450	60		60		120
Base Capacity (vph)	566	1916	900	401	1522	758	253	263	354	334	595
Starvation Cap Reductn	0	0	0	0	0	0	0	0	0	0	0
Spillback Cap Reductn	0	0	0	0	0	0	0	0	0	0	0
Storage Cap Reductn	0	0	0	0	0	0	0	0	0	0	0
Reduced v/c Ratio	0.59	0.39	0.07	0.17	0.49	0.09	0.21	0.20	0.19	0.34	0.62

Intersection Summary

Queues

2020 Total Saturday.syn

2: Dillon Ridge Road & US-6

09/06/2018



Lane Group	EBL	EBT	EBR	WBL	WBT	WBR	NBL	NBT	NBR	SBT	SBR
Lane Group Flow (vph)	511	1044	100	56	878	99	68	71	85	145	578
v/c Ratio	0.80	0.47	0.10	0.20	0.66	0.15	0.85	0.87	0.54	0.55	0.83
Control Delay	35.1	15.7	4.3	16.3	39.5	7.8	128.1	130.3	25.6	59.1	17.1
Queue Delay	0.0	0.0	0.0	0.0	0.0	0.0	0.0	0.0	0.0	0.0	0.0
Total Delay	35.1	15.7	4.3	16.3	39.5	7.8	128.1	130.3	25.6	59.1	17.1
Queue Length 50th (ft)	287	234	5	13	323	0	63	66	0	121	31
Queue Length 95th (ft)	459	405	25	32	#581	36	#122	#162	27	127	75
Internal Link Dist (ft)		740			733			315		111	
Turn Bay Length (ft)	300		150	600		450	60		60		120
Base Capacity (vph)	637	2240	1033	644	1332	657	80	82	157	618	898
Starvation Cap Reductn	0	0	0	0	0	0	0	0	0	0	0
Spillback Cap Reductn	0	0	0	0	0	0	0	0	0	0	0
Storage Cap Reductn	0	0	0	0	0	0	0	0	0	0	0
Reduced v/c Ratio	0.80	0.47	0.10	0.09	0.66	0.15	0.85	0.87	0.54	0.23	0.64

Intersection Summary

95th percentile volume exceeds capacity, queue may be longer.
Queue shown is maximum after two cycles.

Queues
2: Dillon Ridge Road & US-6

2040 BG AM.syn
09/05/2018



Lane Group	EBL	EBT	EBR	WBL	WBT	WBR	NBL	NBT	NBR	SBT	SBR
Lane Group Flow (vph)	193	823	44	20	765	44	22	22	12	24	149
v/c Ratio	0.38	0.32	0.04	0.04	0.32	0.04	0.17	0.16	0.06	0.24	0.65
Control Delay	6.7	7.9	0.2	4.4	9.5	0.2	61.5	61.4	0.6	65.9	22.7
Queue Delay	0.0	0.0	0.0	0.0	0.0	0.0	0.0	0.0	0.0	0.0	0.0
Total Delay	6.7	7.9	0.2	4.4	9.5	0.2	61.5	61.4	0.6	65.9	22.7
Queue Length 50th (ft)	38	138	0	4	137	0	18	18	0	21	0
Queue Length 95th (ft)	47	185	0	8	170	0	33	23	0	50	55
Internal Link Dist (ft)		740			733			315		111	
Turn Bay Length (ft)	300		150	600		450	60		60		120
Base Capacity (vph)	508	2549	1163	485	2396	1099	130	134	201	137	260
Starvation Cap Reductn	0	0	0	0	0	0	0	0	0	0	0
Spillback Cap Reductn	0	0	0	0	0	0	0	0	0	0	0
Storage Cap Reductn	0	0	0	0	0	0	0	0	0	0	0
Reduced v/c Ratio	0.38	0.32	0.04	0.04	0.32	0.04	0.17	0.16	0.06	0.18	0.57

Intersection Summary

Queues
2: Dillon Ridge Road & US-6

2040 BG PM.syn
09/05/2018



Lane Group	EBL	EBT	EBR	WBL	WBT	WBR	NBL	NBT	NBR	SBT	SBR
Lane Group Flow (vph)	292	995	64	68	1000	40	49	51	68	68	329
v/c Ratio	0.70	0.50	0.07	0.21	0.62	0.05	0.19	0.20	0.19	0.42	0.74
Control Delay	23.5	18.1	1.4	12.4	29.3	0.1	47.0	46.9	1.2	57.6	16.0
Queue Delay	0.0	0.0	0.0	0.0	0.0	0.0	0.0	0.0	0.0	0.0	0.0
Total Delay	23.5	18.1	1.4	12.4	29.3	0.1	47.0	46.9	1.2	57.6	16.0
Queue Length 50th (ft)	87	237	0	17	298	0	35	36	0	51	0
Queue Length 95th (ft)	201	350	4	33	#480	0	74	73	0	76	86
Internal Link Dist (ft)		740			733			315		111	
Turn Bay Length (ft)	300		150	600		450	60		60		120
Base Capacity (vph)	515	2005	938	336	1605	792	252	261	353	278	524
Starvation Cap Reductn	0	0	0	0	0	0	0	0	0	0	0
Spillback Cap Reductn	0	0	0	0	0	0	0	0	0	0	0
Storage Cap Reductn	0	0	0	0	0	0	0	0	0	0	0
Reduced v/c Ratio	0.57	0.50	0.07	0.20	0.62	0.05	0.19	0.20	0.19	0.24	0.63

Intersection Summary

95th percentile volume exceeds capacity, queue may be longer.
Queue shown is maximum after two cycles.

Queues
2: Dillon Ridge Road & US-6

2040 BG Saturday.syn
09/06/2018



Lane Group	EBL	EBT	EBR	WBL	WBT	WBR	NBL	NBT	NBR	SBT	SBR
Lane Group Flow (vph)	442	1406	100	56	1183	52	66	66	85	88	504
v/c Ratio	0.76	0.59	0.09	0.24	0.81	0.07	0.82	0.80	0.54	0.44	0.81
Control Delay	44.2	15.4	3.5	13.1	40.4	1.8	123.3	118.7	25.6	60.6	15.8
Queue Delay	0.0	0.0	0.0	0.0	0.0	0.0	0.0	0.0	0.0	0.0	0.0
Total Delay	44.2	15.4	3.5	13.1	40.4	1.8	123.3	118.7	25.6	60.6	15.8
Queue Length 50th (ft)	310	324	4	11	416	0	61	61	0	75	4
Queue Length 95th (ft)	#513	563	23	28	#640	4	#115	#149	27	89	52
Internal Link Dist (ft)		740			733			315		111	
Turn Bay Length (ft)	300		150	600		450	60		60		120
Base Capacity (vph)	581	2373	1089	428	1455	701	80	82	157	927	1057
Starvation Cap Reductn	0	0	0	0	0	0	0	0	0	0	0
Spillback Cap Reductn	0	0	0	0	0	0	0	0	0	0	0
Storage Cap Reductn	0	0	0	0	0	0	0	0	0	0	0
Reduced v/c Ratio	0.76	0.59	0.09	0.13	0.81	0.07	0.82	0.80	0.54	0.09	0.48

Intersection Summary

95th percentile volume exceeds capacity, queue may be longer.
Queue shown is maximum after two cycles.

Queues
2: Dillon Ridge Road & US-6

2040 Total AM.syn
09/05/2018



Lane Group	EBL	EBT	EBR	WBL	WBT	WBR	NBL	NBT	NBR	SBT	SBR
Lane Group Flow (vph)	261	823	44	20	765	86	28	28	12	72	202
v/c Ratio	0.51	0.32	0.04	0.04	0.32	0.08	0.30	0.29	0.07	0.52	0.65
Control Delay	9.0	8.0	0.2	4.5	9.5	1.6	70.0	69.2	0.8	72.8	18.0
Queue Delay	0.0	0.0	0.0	0.0	0.0	0.0	0.0	0.0	0.0	0.0	0.0
Total Delay	9.0	8.0	0.2	4.5	9.5	1.6	70.0	69.2	0.8	72.8	18.0
Queue Length 50th (ft)	55	141	0	4	137	0	25	25	0	62	0
Queue Length 95th (ft)	62	185	0	8	170	6	41	28	0	112	58
Internal Link Dist (ft)		740			733			315		111	
Turn Bay Length (ft)	300		150	600		450	60		60		120
Base Capacity (vph)	508	2551	1164	487	2396	1099	93	97	168	177	340
Starvation Cap Reductn	0	0	0	0	0	0	0	0	0	0	0
Spillback Cap Reductn	0	0	0	0	0	0	0	0	0	0	0
Storage Cap Reductn	0	0	0	0	0	0	0	0	0	0	0
Reduced v/c Ratio	0.51	0.32	0.04	0.04	0.32	0.08	0.30	0.29	0.07	0.41	0.59

Intersection Summary

Queues
2: Dillon Ridge Road & US-6

2040 Total PM.syn
09/05/2018



Lane Group	EBL	EBT	EBR	WBL	WBT	WBR	NBL	NBT	NBR	SBT	SBR
Lane Group Flow (vph)	333	995	64	68	1000	72	52	53	68	115	367
v/c Ratio	0.74	0.49	0.07	0.20	0.64	0.09	0.28	0.27	0.23	0.56	0.72
Control Delay	27.1	17.2	1.4	12.1	30.5	0.2	53.0	52.8	1.8	59.5	13.5
Queue Delay	0.0	0.0	0.0	0.0	0.0	0.0	0.0	0.0	0.0	0.0	0.0
Total Delay	27.1	17.2	1.4	12.1	30.5	0.2	53.0	52.8	1.8	59.5	13.5
Queue Length 50th (ft)	126	235	0	17	313	0	38	40	0	85	0
Queue Length 95th (ft)	240	342	4	31	#480	0	81	80	0	114	90
Internal Link Dist (ft)		740			733			315		111	
Turn Bay Length (ft)	300		150	600		450	60		60		120
Base Capacity (vph)	519	2047	955	348	1570	777	189	196	298	345	602
Starvation Cap Reductn	0	0	0	0	0	0	0	0	0	0	0
Spillback Cap Reductn	0	0	0	0	0	0	0	0	0	0	0
Storage Cap Reductn	0	0	0	0	0	0	0	0	0	0	0
Reduced v/c Ratio	0.64	0.49	0.07	0.20	0.64	0.09	0.28	0.27	0.23	0.33	0.61

Intersection Summary

95th percentile volume exceeds capacity, queue may be longer.
Queue shown is maximum after two cycles.

Queues

2040 Total Saturday.syn

2: Dillon Ridge Road & US-6

09/06/2018



Lane Group	EBL	EBT	EBR	WBL	WBT	WBR	NBL	NBT	NBR	SBT	SBR
Lane Group Flow (vph)	511	1406	100	56	1183	99	68	71	85	145	578
v/c Ratio	0.76	0.63	0.10	0.27	1.04	0.17	0.85	0.87	0.54	0.54	0.83
Control Delay	40.6	19.1	4.3	18.7	81.2	8.2	128.1	130.3	25.6	58.9	16.2
Queue Delay	0.0	0.0	0.0	0.0	0.0	0.0	0.0	0.0	0.0	0.0	0.0
Total Delay	40.6	19.1	4.3	18.7	81.2	8.2	128.1	130.3	25.6	58.9	16.2
Queue Length 50th (ft)	356	371	5	13	503	2	63	66	0	121	26
Queue Length 95th (ft)	#552	631	26	32	#840	37	#122	#162	27	127	68
Internal Link Dist (ft)		740			733			315		111	
Turn Bay Length (ft)	300		150	600		450	60		60		120
Base Capacity (vph)	670	2238	1032	475	1138	574	80	82	157	818	1017
Starvation Cap Reductn	0	0	0	0	0	0	0	0	0	0	0
Spillback Cap Reductn	0	0	0	0	0	0	0	0	0	0	0
Storage Cap Reductn	0	0	0	0	0	0	0	0	0	0	0
Reduced v/c Ratio	0.76	0.63	0.10	0.12	1.04	0.17	0.85	0.87	0.54	0.18	0.57

Intersection Summary

95th percentile volume exceeds capacity, queue may be longer.
Queue shown is maximum after two cycles.

APPENDIX F

Conceptual Site Plan

DRAWN BY	CR
CHECKED	JP
JOB NO.	1821
DATE	8-16-2018
REVISIONS	

PANERA
DILLON, COLORADO

CLAVONNE, ROBERTS & ASSOCIATES, INC.
LAND PLANNING AND
LANDSCAPE ARCHITECTURE
222 N. 7TH STREET
GRAND JUNCTION, CO 81501
970-241-0745 P
970-241-0765 F
www.clavonne.com

PANERA
DILLON,
COLORADO

CONCEPT SITE PLAN

SHEET NO.

11

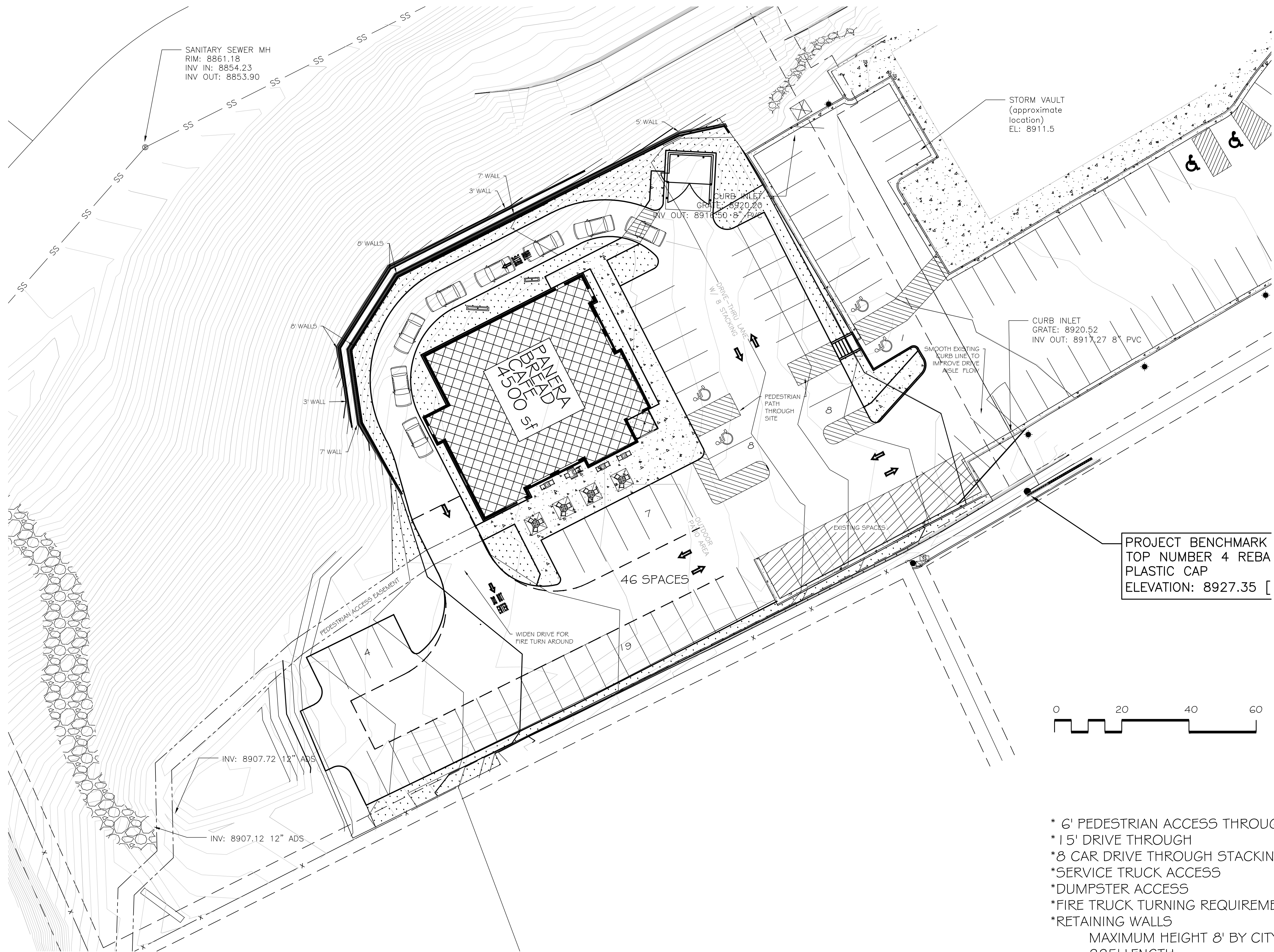

- * 6' PEDESTRIAN ACCESS THROUGH SITE
- * 15' DRIVE THROUGH
- * 8' CAR DRIVE THROUGH STACKING
- * SERVICE TRUCK ACCESS
- * DUMPSTER ACCESS
- * FIRE TRUCK TURNING REQUIREMENT
- * RETAINING WALLS
MAXIMUM HEIGHT 8' BY CITY STANDARD
225' LENGTH
- * SNOW STORAGE AND DETENTION BASIN SPACE
- * 46 PARKING SPACES
- * LANDSCAPABLE AREAS SHOWN